

EUF2540MHW

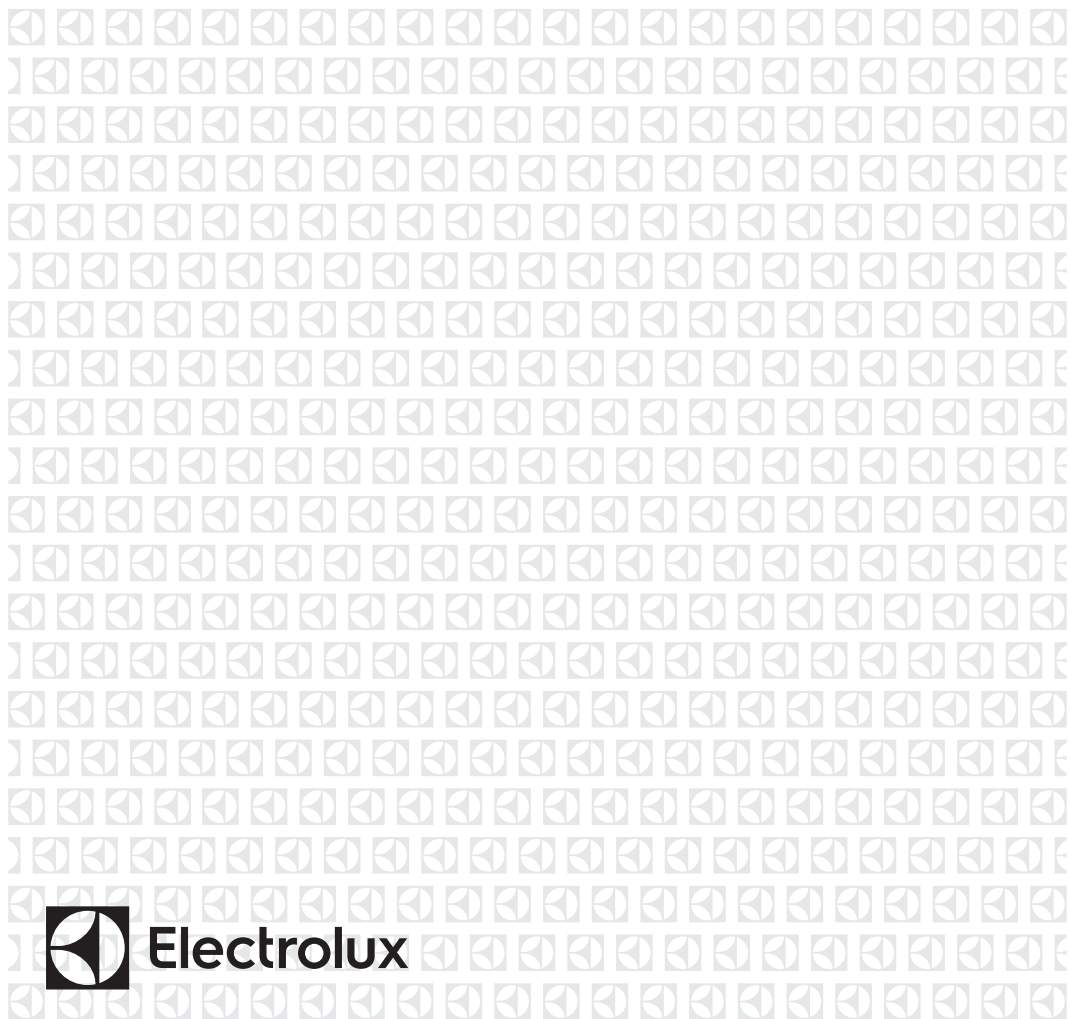

EN Freezer

User Manual



Electrolux

CONTENTS

1. SAFETY INFORMATION.....	2
2. SAFETY INSTRUCTIONS.....	4
3. OPERATION.....	5
4. DAILY USE.....	6
5. HINTS AND TIPS.....	8
6. CARE AND CLEANING.....	9
7. TROUBLESHOOTING.....	10
8. INSTALLATION.....	12
9. NOISES.....	14
10. TECHNICAL INFORMATION.....	16

WE'RE THINKING OF YOU

Thank you for purchasing an Electrolux appliance. You've chosen a product that brings with it decades of professional experience and innovation. Ingenious and stylish, it has been designed with you in mind. So whenever you use it, you can be safe in the knowledge that you'll get great results every time.

Welcome to Electrolux.

Visit our website for:



Get usage advice, brochures, trouble shooter, service information:
www.electrolux.com



Register your product for better service:
www.registerelectrolux.com



Buy Accessories, Consumables and Original spare parts for your appliance:
www.electrolux.com/shop

CUSTOMER CARE AND SERVICE

Always use original spare parts.

When contacting our Authorised Service Centre, ensure that you have the following data available: Model, PNC, Serial Number.

The information can be found on the rating plate.



Warning / Caution-Safety information



General information and tips



Environmental information

Subject to change without notice.

1. ⚠ SAFETY INFORMATION

Before the installation and use of the appliance, carefully read the supplied instructions. The manufacturer is not responsible if an incorrect installation and use causes

injuries and damages. Always keep the instructions with the appliance for future reference.

1.1 Children and vulnerable people safety

- This appliance can be used by children aged from 8 years and above and persons with reduced physical, sensory or mental capabilities or lack of experience and knowledge if they have been given supervision or instruction concerning use of the appliance in a safe way and understand the hazards involved.
- Do not let children play with the appliance.
- Cleaning and user maintenance shall not be made by children without supervision.
- Keep all packaging away from children.

1.2 General Safety

- This appliance is intended to be used in household and similar applications such as:
 - Farm houses; staff kitchen areas in shops, offices and other working environments
 - By clients in hotels, motels, bed and breakfast and other residential type environments
- Keep ventilation openings, in the appliance enclosure or in the built-in structure, clear of obstruction.
- Do not use mechanical devices or other means to accelerate the defrosting process, other than those recommended by the manufacturer.
- Do not damage the refrigerant circuit.
- Do not use electrical appliances inside the food storage compartments of the appliance, unless they are of the type recommended by the manufacturer.
- Do not use water spray and steam to clean the appliance.
- Clean the appliance with a moist soft cloth. Only use neutral detergents. Do not use abrasive products, abrasive cleaning pads, solvents or metal objects.

- Do not store explosive substances such as aerosol cans with a flammable propellant in this appliance.
- If the supply cord is damaged, it must be replaced by the manufacturer, its Authorised Service Centre or similarly qualified persons in order to avoid a hazard.

2. SAFETY INSTRUCTIONS

2.1 Installation



WARNING!

Only a qualified person must install this appliance.

- Remove all the packaging.
- Do not install or use a damaged appliance.
- Obey the installation instruction supplied with the appliance.
- Always be careful when you move the appliance because it is heavy. Always wear safety gloves.
- Make sure the air can circulate around the appliance.
- Wait at least 4 hours before connecting the appliance to the power supply. This is to allow the oil to flow back in the compressor.
- Do not install the appliance close to radiators or cookers, oven or hobs.
- The rear of the appliance must stand against the wall.
- Do not install the appliance where there is direct sunlight.
- Do not install this appliance in areas that are too humid or too colds, such as the construction appendices, garages or wine cellars.
- When you move the appliance, lift it by the front edge to avoid scratching the floor.

2.2 Electrical connection



WARNING!

Risk of fire and electrical shock.

- The appliance must be earthed.
- Make sure that the electrical information on the rating plate agrees with the power supply. If not, contact an electrician.

- Always use a correctly installed shockproof socket.
- Do not use multi-plug adapters and extension cables.
- Make sure not to cause damage to the electrical components (e.g. mains plug, mains cable, compressor). Contact the Authorised Service Centre or an electrician to change the electrical components.
- The mains cable must stay below the level of the mains plug.
- Connect the mains plug to the mains socket only at the end of the installation. Make sure that there is access to the mains plug after the installation.
- Do not pull the mains cable to disconnect the appliance. Always pull the mains plug.

2.3 Use



WARNING!

Risk of injury, burns, electrical shock or fire.

- Do not change the specification of this appliance.
- Do not put electrical appliances (e.g. ice cream makers) in the appliance unless they are stated applicable by the manufacturer.
- Be careful not to cause damage to the refrigerant circuit. It contains isobutane (R600a), a natural gas with a high level of environmental compatibility. This gas is flammable.
- If damage occurs to the refrigerant circuit, make sure that there are no flames and sources of ignition in the room. Ventilate the room.
- Do not let hot items to touch the plastic parts of the appliance.

- Do not put soft drinks in the freezer compartment. This will create pressure on the drink container.
- Do not store flammable gas and liquid in the appliance.
- Do not put flammable products or items that are wet with flammable products in, near or on the appliance.
- Do not touch the compressor or the condenser. They are hot.
- Do not remove or touch items from the freezer compartment if your hands are wet or damp.
- Do not freeze again food that has been thawed.
- Obey the storage instructions on the packaging of frozen food.

2.4 Care and cleaning



WARNING!

Risk of injury or damage to the appliance.

- Before maintenance, deactivate the appliance and disconnect the mains plug from the mains socket.
- This appliance contains hydrocarbons in the cooling unit. Only a qualified person must do the maintenance and the recharging of the unit.

- Regularly examine the drain of the appliance and if necessary, clean it. If the drain is blocked, defrosted water collects in the bottom of the appliance.

2.5 Disposal



WARNING!

Risk of injury or suffocation.

- Disconnect the appliance from the mains supply.
- Cut off the mains cable and discard it.
- Remove the door to prevent children and pets to be closed inside of the appliance.
- The refrigerant circuit and the insulation materials of this appliance are ozone-friendly.
- The insulation foam contains flammable gas. Contact your municipal authority for information on how to discard the appliance correctly.
- Do not cause damage to the part of the cooling unit that is near the heat exchanger.

3. OPERATION

3.1 Control Panel

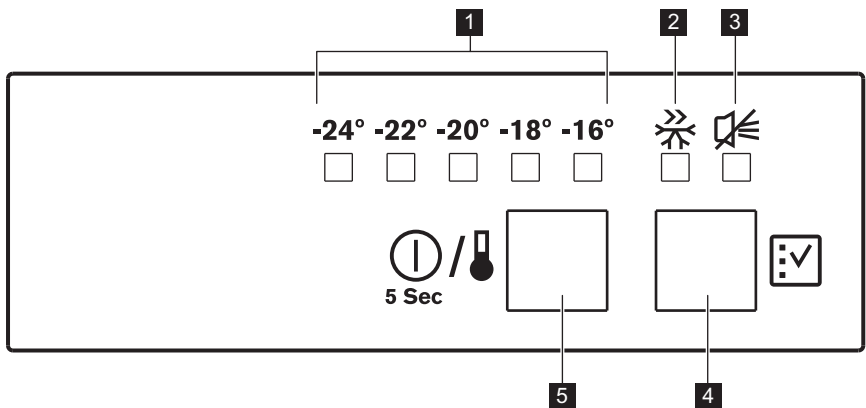

1 Temperature indicators

2 ActionFreeze light

- 3 Alarm light
- 4 Alarm reset button/
ActionFreeze button
- 5 ON/OFF/
Temperature set button

3.2 Switching on

Insert the plug into the wall socket.



If the Temperature indicator is not illuminated, press ON/OFF button.

If the Temperature inside the appliance is too warm the Alarm light will flash and the Alarm buzzer starts.

Press the Alarm reset button to switch off the Alarm buzzer.

3.3 Switching off

1. Press the ON/OFF button for few seconds.
All Temperature indicators will light up and then count down in 3 steps.
2. Disconnect the mains plug from the mains socket to disengage the appliance completely.

3.4 Temperature regulation

1. Press the Temperature set button.
The temperature indicator will flash.
2. Select a new temperature by pressing the Temperature set button repeatedly.
3. The Temperature indicator will stop flashing after a while.



The temperature indicator shows the set temperature. The set temperature will be reached within 24 hours.

Keep in mind that the temperature inside the appliance also depends on:

- room temperature
- how often the door is opened
- quantity of food stored
- location of the appliance.

3.5 High temperature alarm

Temperature increase in the freezer compartment (for example due to an earlier power failure or door is open) is indicated by:

- alarm light flashing.
- sounding of buzzer.

The buzzer can be switched off by pressing the alarm reset button.

When normal conditions are restored the alarm light will stop flashing and the buzzer turn off automatically.

3.6 ActionFreeze function

Press the ActionFreeze button. The ActionFreeze light will light up.



This function stops automatically after approximately 52 hours. It is possible to deactivate the function at any time by pressing the ActionFreeze button. The ActionFreeze light will switch off.

4. DAILY USE



WARNING!
Refer to Safety chapters.

4.1 Freezing fresh food

The freezer compartment is suitable for freezing fresh food and storing frozen and deep-frozen food for a long time.

To freeze small amount of fresh foods it is not necessary to change the present setting.

To freeze fresh food activate the ActionFreeze function at least 24 hours before placing the food to be frozen in the freezer compartment.

Place the fresh food to be frozen in all compartments except the lowest one.

The maximum amount of food that can be frozen in 24 hours is specified on the rating plate, a label located on the inside of the appliance.

The freezing process lasts 24 hours: during this period do not add other food to be frozen.

4.2 Storage of frozen food

When first starting-up or after a period out of use, let the appliance run at least 2 hours before putting products in the freezer compartment.

The freezer baskets ensure that it is quick and easy to find the food packages you want. If large quantities of food are to be stored, remove all drawers except for the bottom basket which secures good air circulation.

It is possible to place food that protrudes 15 mm from the door on all shelves except the top one.

i In the event of accidental defrosting, for example due to a power failure, if the power has been off for longer than the value shown in the technical characteristics chart under "rising time", the defrosted food must be consumed quickly or cooked immediately and then re-frozen (after cooling).

4.3 Thawing

Deep-frozen or frozen food, prior to being used, can be thawed in the refrigerator compartment or at room temperature, depending on the time available for this operation.

Small pieces may even be cooked still frozen, directly from the freezer: in this case, cooking will take longer.

4.4 Removal of freezing baskets and glass shelves from the freezer

The freezing baskets have a limit stop to prevent their accidental removal or falling out. At the time of its removal from the freezer, pull the basket towards yourself and, upon reaching the end point, remove the basket by tilting its front upwards.

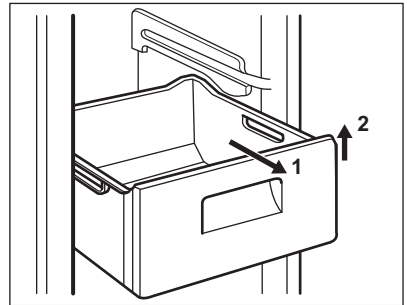

At the time of putting it back, slightly lift the front of the basket to insert it into the freezer. Once you are over the end points, push the baskets back in their position.

The appliance is equipped with shelf stops to secure the shelves.

The shelves must be lifted up (1) on each side and then pulled outwards (2).

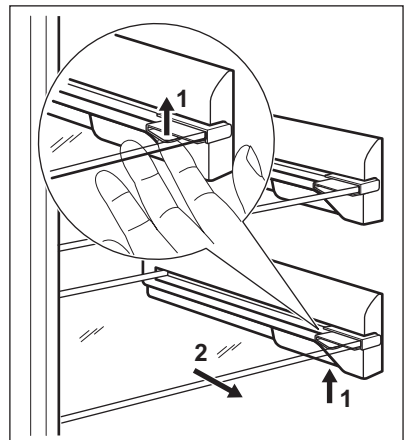

4.5 Cleaning the interior

1. Before using the appliance for the first time, wash the interior and all internal accessories with lukewarm water and neutral soap so as to remove the typical smell of a brand-new product, then dry thoroughly.
2. Check that the drain hose at the rear of the cabinet discharges into the drip tray.

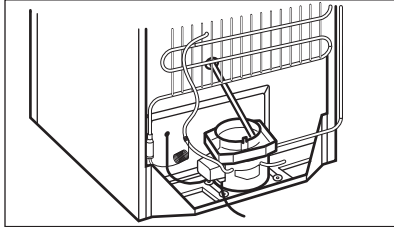

CAUTION!

Do not use detergents or abrasive powders, as these will damage the finish.

5. HINTS AND TIPS

5.1 Normal operating sounds

The following sounds are normal during operation:

- A faint gurgling and bubbling sound from coils sound when refrigerant is pumped.
- A whirring and pulsating sound from the compressor when refrigerant is pumped.
- A sudden cracking noise from inside appliance caused by thermic dilatation (a natural and not dangerous physical phenomenon).
- A faint click noise from the temperature regulator when the compressor switches on or off.

5.2 Hints for energy saving

- Do not open the door frequently or leave it open longer than absolutely necessary.

5.3 Hints for freezing

To help you make the most of the freezing process, here are some important hints:

- the maximum quantity of food which can be frozen in 24 hours is shown on the rating plate;
- the freezing process takes 24 hours no further food to be frozen should be added during this period;
- freeze only top quality, fresh and thoroughly cleaned, foodstuffs;
- prepare food in small portions to enable it to be rapidly and completely frozen and to make it possible subsequently to thaw only the quantity required;
- wrap up the food in aluminium foil or polythene and make sure that the packages are airtight;
- do not allow fresh, unfrozen food to touch food which is already frozen, thus avoiding a rise in temperature of the latter;
- lean foods store better and longer than fatty ones; salt reduces the storage life of food;
- water ices, if consumed immediately after removal from the freezer compartment, can possibly cause the skin to be freeze burnt;
- it is advisable to show the freezing in date on each individual pack to enable you to keep tab of the storage time.

5.4 Hints for storage of frozen food

To obtain the best performance from this appliance, you should:

- make sure that the commercially frozen foodstuffs were adequately stored by the retailer;
- be sure that frozen foodstuffs are transferred from the foodstore to the freezer in the shortest possible time;

- not open the door frequently or leave it open longer than absolutely necessary;
- once defrosted, food deteriorates rapidly and cannot be refrozen;
- do not exceed the storage period indicated by the food manufacturer.

6. CARE AND CLEANING



WARNING!
Refer to Safety chapters.

6.1 General warnings



CAUTION!
Unplug the appliance before carrying out any maintenance operation.



This appliance contains hydrocarbons in its cooling unit; maintenance and recharging must therefore only be carried out by authorized technicians.



The accessories and parts of the appliance are not suitable for washing in a dishwasher.

6.2 Periodic cleaning



CAUTION!
Do not pull, move or damage any pipes and/or cables inside the cabinet.



CAUTION!
Take care of not to damage the cooling system.



CAUTION!
When moving the cabinet, lift it by the front edge to avoid scratching the floor.

The equipment has to be cleaned regularly:

1. Clean the inside and accessories with lukewarm water and some neutral soap.
2. Regularly check the door seals and wipe clean to ensure they are clean and free from debris.
3. Rinse and dry thoroughly.
4. If accessible, clean the condenser and the compressor at the back of the appliance with a brush. This operation will improve the performance of the appliance and save electricity consumption.

6.3 Defrosting the freezer

The freezer compartment is frost free. This means that there is no build up of frost when it is in operation, neither on the internal walls nor on the foods.

The absence of frost is due to the continuous circulation of cold air inside the compartment, driven by an automatically controlled fan.

6.4 Cleaning the ventilation grille

Make sure the door is open.

The ventilation grille can be removed for washing.

1. Loosen the edge of the grille by pulling it according to the figure.

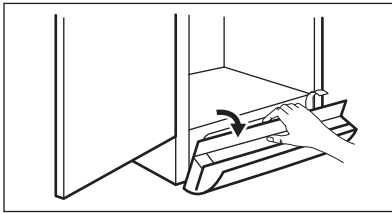

2. Pull the grille straight out to completely remove it.
3. Vacuum clean under the cabinet.

6.5 Periods of non-operation

When the appliance is not in use for long periods, take the following precautions:

1. Disconnect the appliance from electricity supply.
2. Remove all food.
3. Clean the appliance and all accessories.
4. Leave the door/doors open to prevent unpleasant smells.



WARNING!

If the cabinet will be kept on, ask somebody to check it once in a while to prevent the food inside from spoiling in case of a power failure.

7. TROUBLESHOOTING



WARNING!

Refer to Safety chapters.

7.1 What to do if...

Problem	Possible cause	Solution
The appliance does not operate.	The appliance is switched off.	Switch on the appliance.
	The mains plug is not connected to the mains socket correctly.	Connect the mains plug to the mains socket correctly.
	There is no voltage in the mains socket.	Connect a different electrical appliance to the mains socket. Contact a qualified electrician.
The appliance is noisy.	The appliance is not supported properly.	Check if the appliance stands stable.
Audible or visual alarm is on.	The cabinet has been recently switched on or the temperature is still too high.	Refer to "High temperature alarm".
	The temperature in the appliance is too high.	Refer to "High temperature alarm".
Three temperature indicators flashing.	An error has occurred in measuring the temperature.	Contact the nearest Authorised Service Centre (the cooling system will continue to keep food products cold, but temperature adjustment will not be possible).

Problem	Possible cause	Solution
The compressor operates continually.	Temperature is set incorrectly.	Refer to "Operation" chapter.
	Many food products were put in at the same time.	Wait some hours and then check the temperature again.
	The room temperature is too high.	Refer to climate class chart on the rating plate.
	Food products placed in the appliance were too warm.	Allow food products to cool to room temperature before storing.
	The door is not closed correctly.	Refer to "Closing the door".
	The ActionFreeze function is switched on.	Refer to "ActionFreeze function".
The compressor does not start immediately after pressing the ActionFreeze, or after changing the temperature.	This is normal, no error has occurred.	The compressor starts after a period of time.
Water flows on the floor.	The melting water outlet is not connected to the evaporative tray above the compressor.	Attach the melting water outlet to the evaporative tray.
Temperature cannot be set.	The ActionFreeze function is switched on.	Switch off ActionFreeze manually, or wait until the function resets automatically to set the temperature. Refer to "ActionFreeze function".
Door is misaligned or interferes with ventilation grill.	The appliance is not levelled.	Refer to "Levelling".
The temperature in the appliance is too low/too high.	The temperature regulator is not set correctly.	Set a higher/lower temperature.
	Food products placed in the appliance were too warm.	Allow food products to cool to room temperature before storing.
	The door has been opened often.	Open the door only if necessary.
	The ActionFreeze function is switched on.	Refer to "ActionFreeze function".
	There is no cold air circulation in the appliance.	Make sure that there is cold air circulation in the appliance.



If the advice does not lead to the desired result, call the nearest Authorised Service Centre.

7.2 Closing the door

1. Clean the door gaskets.

8. INSTALLATION



WARNING!
Refer to Safety chapters.

8.1 Positioning

This appliance can be installed in a dry, well ventilated indoor where the ambient temperature corresponds to the climate class indicated on the rating plate of the appliance:

Climate class	Ambient temperature
SN	+10°C to + 32°C
N	+16°C to + 32°C
ST	+16°C to + 38°C
T	+16°C to + 43°C



Some functional problems might occur for some types of models when operating outside of that range. The correct operation can only be guaranteed within the specified temperature range. If you have any doubts regarding where to install the appliance, please turn to the vendor, to our customer service or to the nearest Authorised Service Centre.

8.2 Electrical connection

- Before plugging in, ensure that the voltage and frequency shown on the rating plate correspond to your domestic power supply.
- The appliance must be earthed. The power supply cable plug is provided

2. If necessary, adjust the door. Refer to "Installation".
3. If necessary, replace the defective door gaskets. Contact the Authorised Service Centre.

with a contact for this purpose. If the domestic power supply socket is not earthed, connect the appliance to a separate earth in compliance with current regulations, consulting a qualified electrician.

- The manufacturer declines all responsibility if the above safety precautions are not observed.
- This appliance complies with the E.E.C. Directives.

8.3 Location

To ensure best performance, if the appliance is positioned below an overhanging wall unit, the minimum distance between the top of the cabinet and the wall unit must be at least 40 mm. Ideally, however, the appliance should not be positioned below overhanging wall units.

The ventilation space can be:

- directly above the appliance
- behind and above the top cupboard. In this case, the space behind the top cupboard must be at least 50 mm deep.

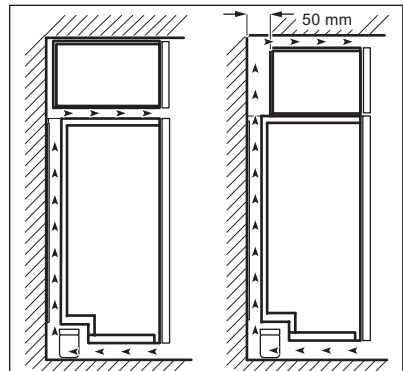

8.4 Removing the transport support

Your appliance is equipped with transport support to secure the door during transportation.

1. Open the door.
2. Remove the transport support from the door sides.
3. Remove the transport support from the lower hinge (some models).

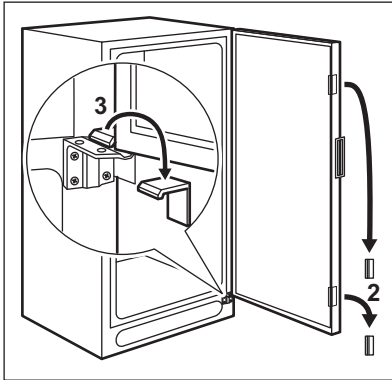

Some models are fitted with a silencing pad under the cabinet. Do not remove this pad.

8.5 Levelling

When placing the appliance ensure that it stands level. If necessary adjust the feet using an adjustment spanner.

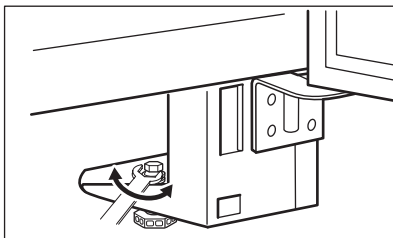

On some models the wheels in the backside can be adjusted by turning the nut on the threaded rod to the left to raise the appliance and to the right to lower the appliance.

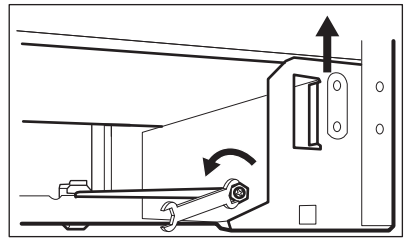

Door alignment is dependent on proper levelling.

8.6 Door reversibility



WARNING!

Before carrying out any operations, remove the plug from the power socket.

1. Remove the ventilation grille. Remove the filling and install it on the opposite side of the grille.
2. Lay down the appliance back side down on a wooden support.
3. Unscrew the upper hinge (A1) and the cover washer (A2) and install this on the opposite side.

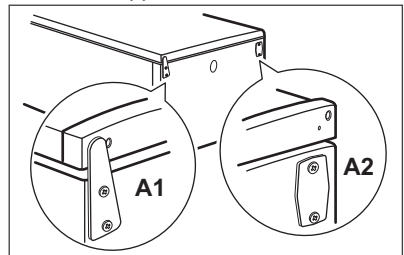

4. Unscrew the lower hinge (1). Move the pin to the opposite side (2).

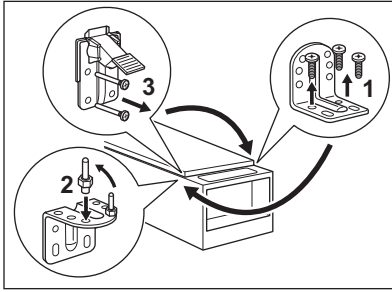

5. Unscrew and move the pedal to the opposite side (3).
6. Unscrew and move the bracket to the other side on the door.

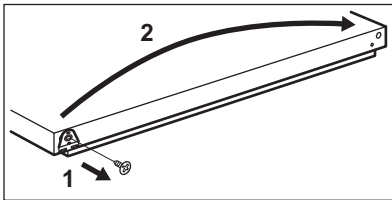

7. Screw on the lower hinge on the opposite side.
8. Tighten the pin with the adjustment spanner supplied.
9. Raise the appliance and install the ventilation grille.
10. Unscrew the handle. On the opposite side remove the hole covers by driving a 3-4 mm drift or drill into them. Install the handle.

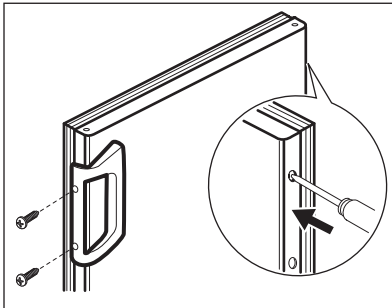

9. NOISES

There are some sounds during normal running (compressor, refrigerant circulation).

11. Install the hole covers provided within the accessory bag.



CAUTION!

Reposition, level the appliance, wait for at least four hours and then connect it to the power socket.



Do a final check to make sure that:

- All screws are tightened.
- The magnetic seal adheres to the cabinet.
- The door opens and closes correctly.

If the ambient temperature is cold (i.e. in Winter), the gasket may not fit perfectly to the cabinet. In that case, wait for the natural fitting of the gasket.

In case you do not want to carry out the above mentioned operations, contact the nearest Authorised Service Centre. The Authorised Service specialist will carry out the reversibility of the doors at your cost.

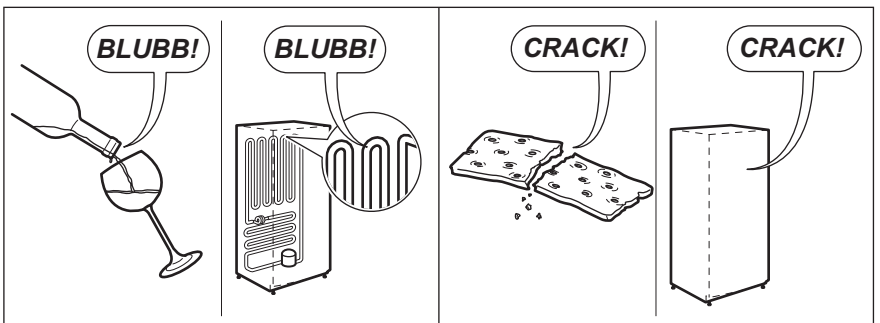
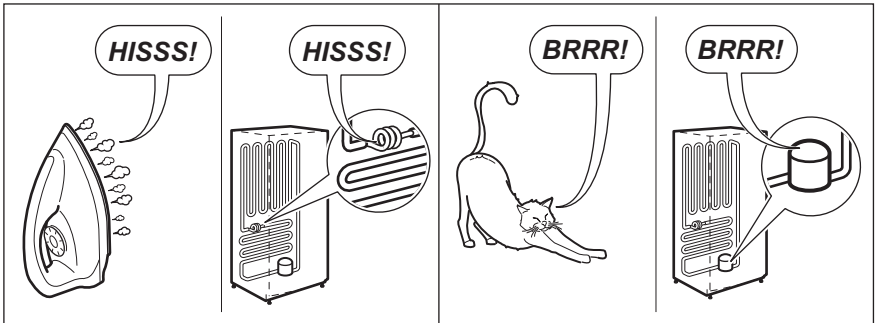
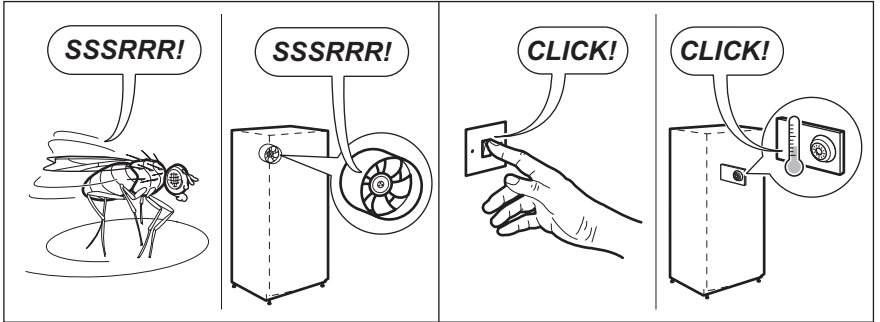
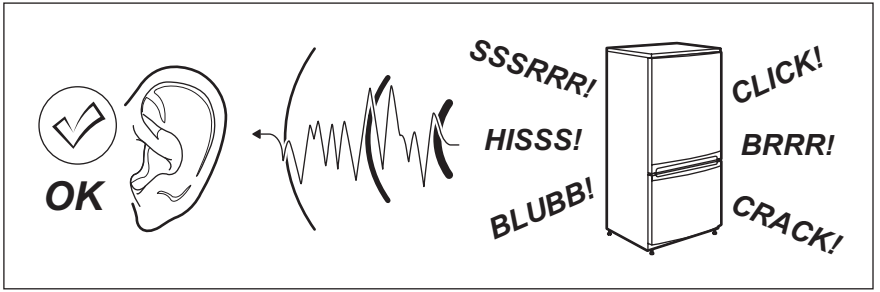

10. TECHNICAL INFORMATION

10.1 Technical data

Height	mm	1550
Width	mm	595
Depth	mm	623
Rising time	Hours	12
Voltage	Volts	230 - 240
Frequency	Hz	50

The technical information are situated in the rating plate, on the external or

internal side of the appliance and in the energy label.

11. ENVIRONMENT CONCERNS

Recycle the materials with the symbol . Put the packaging in applicable containers to recycle it. Help protect the environment and human health and to recycle waste of electrical and electronic appliances. Do not dispose appliances

marked with the symbol  with the household waste. Return the product to your local recycling facility or contact your municipal office.

www.electrolux.com/shop



298377123-A-232015

