

EN User manual

2

# USER MANUAL

Cooker hood

ZHI611G UK

*la vita è bella*  
**ZANUSSI**  
ITALIAN SINCE 1916

Thank you for buying a Zanussi product.

To enable you to use your appliance effectively and safely, please read this instruction book carefully before using the appliance and retain for future reference. If you require guidance in the use of the appliance or require further information on Zanussi Products, please contact our Customer Services Department. For general enquiries concerning your Zanussi appliance or for further information, visit our website at <http://www.zanussi.co.uk>

Customer Services Department  
Major Appliances  
Zanussi  
Addington Way  
Luton  
Bedfordshire  
LU4 9QQ

Tel: 08705 727 727\*

\* calls to this number may be recorded for training purposes.

To register ownership, please ensure you complete and return the guarantee card supplied with the appliance.

## For the User

### Important Safety Information

### Your Appliance

### Operating Instructions

Cooker Hood Controls

To Operate

Extraction mode

Recirculation

### Maintenance and Cleaning

External Cleaning

Synthetic Paper Grease Filter

To Replace the Synthetic Paper Grease Filter

Charcoal Filter (Optional Extra)

To Remove the Charcoal Filter

Changing the Light Bulb

### Something Not Working

### Service and Spare Parts

### Guarantee Conditions

## For the Installer

### Installation Instructions

Technical Information

### Electrical Connections

Electrical Requirements

Electrical Connection

### Installing the Cooker Hood

Installation Requirements

Ducting

Clearance Height

Unpacking

Fitting the Wall Brackets

Venting

To Fit the Ducting

Recirculation

Fitting the Cooker Hood to the Wall

Decor Panel

Fitting a Decor Panel to the Hood Visor

To Refit the Hood With Decor Panel Attached

Adjustment

## Guide to use the instruction book

The following Symbols will be found in the text to guide you through the instruction book



Safety instructions



Step by step instructions

## IMPORTANT SAFETY INFORMATION

These warnings are provided in the interests of your safety. Ensure that you understand them all before installing or using this appliance. Your safety is of paramount importance. If you are unsure about any of the meanings of these warnings contact the Customer Services Department.

### ■ Installation

- Any installation work must be undertaken by a qualified electrician or a competent person.
- This hood must be installed in accordance with the installation instructions and all measurements must be adhered to.
- If the cooker hood is installed for use above a gas appliance then the provision for ventilation must be in accordance with the Gas Safety Codes of Practice BS.6172, BS.5440 and BS.6891 (Natural Gas) and BS.5482 (LP Gas) 1994, the Gas Safety (Installation & Use) Regulations, the Building Regulations issued by the Department of the Environment, the Building standards (Scotland) (Consolidated) Regulations issued by the Scottish Development Department.
- The fan motor of this cooker hood incorporates a cut-out device which will operate if the cooker hood is installed below the minimum height recommended under section 'Clearance Height', or if the motor becomes overheated. If the cut-out device is activated, switch off the fan motor and allow the cooker hood to cool. The cut-out device will reset itself when the fan motor has cooled significantly.
- It is dangerous to alter the specifications or modify this product in any way.
- When installed between adjoining wall cabinets the wall cabinets must not overhang the hob.
- If the room where the hood is to be used contains a fuel burning appliance such as a central heating boiler then its flue must be of the room sealed or balanced flue type.
- If other types of flue or appliances are fitted ensure that there is an adequate supply of air to the room.
- The ducting system for this appliance must not be connected to any existing ventilation system which is being used for any other purpose.
- Do not install above a cooker with a high level grill.

### ■ Child Safety

- This appliance is designed to be operated by adults. Children should not be allowed to tamper with the controls or play with the appliance.

### ■ During Use

- This product is for domestic use only.
- Never leave frying pans unattended during use as over-heated fats and oils might catch fire.
- Never do flambé cooking under this cooker hood.
- Do not leave naked flames under the hood.

### ■ Maintenance and Service

- This appliance can be a hazard if the synthetic paper and charcoal filters are not replaced as recommended.
- Under no circumstances should you attempt to repair the appliance yourself. Repairs carried out by inexperienced persons may cause injury or more serious malfunction. Refer to your local Zanussi Service Force Centre. Always insist on genuine spare parts.

## YOUR APPLIANCE

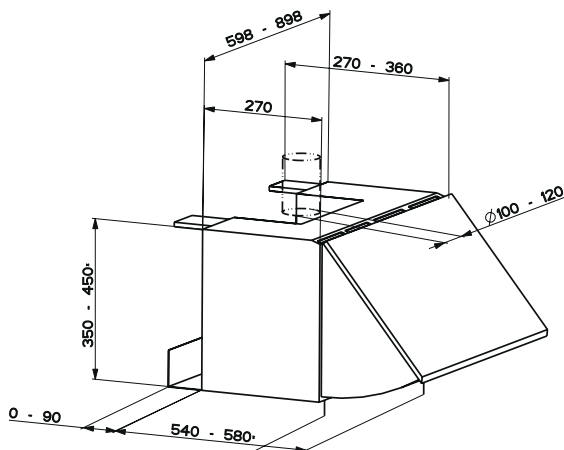

## OPERATING INSTRUCTIONS

This cooker hood is designed to extract unpleasant odours from the kitchen, it will not extract steam.

To obtain the best performance it is advisable to switch on the hood a few minutes before you start cooking and leave it running for approximately 15 minutes after finishing.

The cooker hood controls are located on the right hand side.

### The Controls

#### I. Automatic Microswitch

The microswitch overrides the controls, and switches off the hood when the visor is closed. When the visor is opened the hood will resume the function of previous setting.

#### M. Fan ON/OFF control

#### Y. Fan Speed Control

Position 1 - Low

Position 2 - Normal

Position 3 - Boost

#### L. Light ON/OFF control

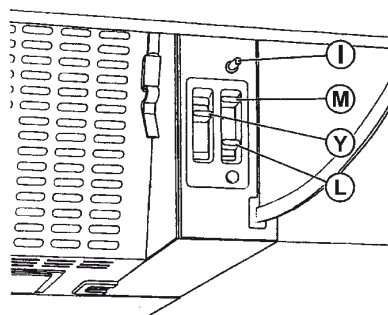

## To operated

The appliance can be installed to recirculate or extract contaminated air. The cooker hood is more effective when used in the extraction mode.

### Recirculation

In the recirculation mode contaminated air is passed through the charcoal filter to be purified and recirculated into the kitchen.

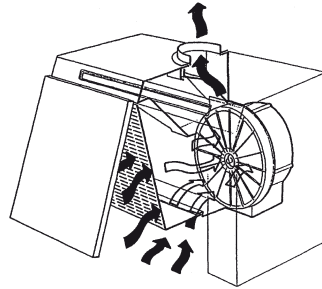

### Extraction

In the extraction mode contaminated air enters the cooker hood, passes through the grease filter and out through the ducting into the atmosphere.



*When the ducting position is selected the charcoal filter is not required.*

*Never do flambé cooking under this cooker hood.*

*Take extra care when frying and never leave frying pans unattended during use as overheated fats and oils might catch fire.*

*Do not leave naked flames under the cooker hood.*

*Ensure heating areas on your hob are covered with pots and pans when using the hob and cooker hood simultaneously.*

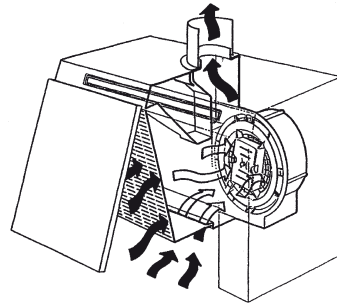

## MAINTENANCE AND CLEANING

 Before carrying out any maintenance or cleaning isolate the cooker hood from the mains supply.

*The cooker hood must be kept clean, a build up of grease or fat can be a fire hazard.*

### **External Cleaning**

Wipe the cooker hood frequently with warm soapy water using a mild detergent.

 Always wear protective gloves when cleaning the hood.

*Never use scouring pads or abrasive cleaners.*

*Never use excessive amounts of water when cleaning particularly around the control panel.*

### **Synthetic Paper Grease Filter**

 The synthetic paper grease filter cannot be cleaned.

**It must not be washed.**

### **To Replace the Synthetic Paper Grease Filter**

1. Open the metal grille pushing the knobs towards the centre while pulling downwards..
4. Remove the wire clips and remove the filters.

*Handle the wire clips with care and keep away from children as they have sharp points.*

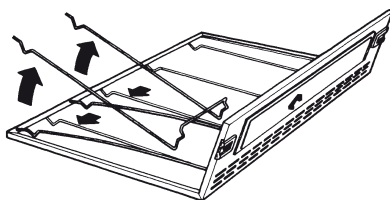
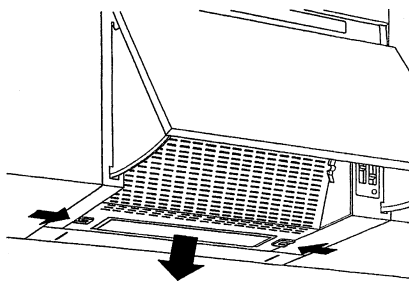

## Charcoal Filter

The charcoal filter cannot be cleaned.

The filter should be replaced at least every three months or more frequently if the hood is used more than three hours per day.

### **To Remove/Replace the Charcoal Filter**

1. Open the metal grille pushing the knobs towards the centre while pulling downwards.
2. support the filter with one hand, remove the round disk through the centre of the charcoal filter and rotate it till the filter will come away.
3. Replace by reversing the operation.

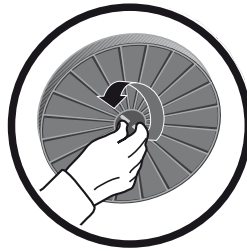
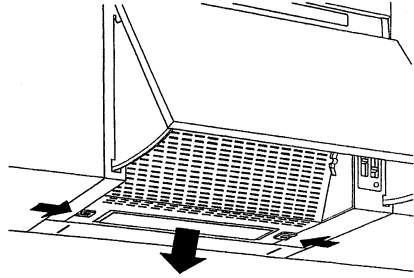

## Changing the Light Bulb

If a lamp fails to function check that the bulb is screwed into the holder.

If bulb failure has occurred then it should be replaced with a 220-240V 40W clear cylindrical shape bulb with a small E14 screw thread.

**Charcoal filters, grease filters and light bulbs can be obtained from your local Service Force Centre**

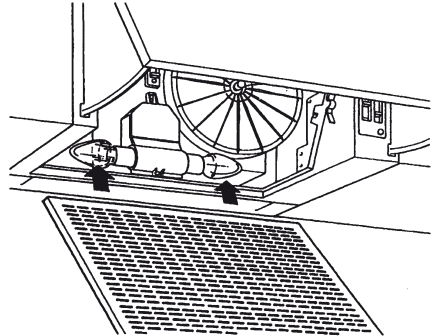

*This appliance can be a fire hazard if the grease and charcoal filters are not cleaned and replaced as recommended.*

## SOMETHING NOT WORKING

If, having followed these instructions carefully, your cooker hood fails to work properly please carry out the following checks.

Symptom	Solution
<b>The cooker hood will not start</b>	<ul style="list-style-type: none"> <li>• Check the hood is connected to the electricity supply.</li> <li>• Check that the fan speed control is set to 1, 2 or 3.</li> </ul>
<b>The cooker hood is not working effectively</b>	<ul style="list-style-type: none"> <li>• The fan speed is set high enough for the task.</li> <li>• The grease filter is clean.</li> <li>• The kitchen is adequately vented to allow the entry of fresh air.</li> <li>• If set up for recirculation, check that the charcoal filter is still effective.</li> <li>• If set up for extraction, check that the ducting and outlets are not blocked.</li> </ul>
<b>The cooker hood has switched off during operation</b>	<ul style="list-style-type: none"> <li>• The safety cut-out device has been tripped.</li> <li>• Turn off the hob and then wait for the device to re-set.</li> </ul>

If after all these checks, the problem persists, contact your local Service Force Centre, quoting the model and serial number.

Please note that it will be necessary to provide proof of purchase for any in-guarantee service calls.

**In-guarantee customers should ensure that the above checks have been made as the engineer will make a charge if the fault is not a mechanical or electrical breakdown.**

## SERVICE AND SPARE PARTS

If you require an engineer or wish to purchase spare parts contact your local Service Force Centre by telephoning:

**08705 929929**

Your telephone call will be routed to your local Service Force Centre. For further details please see the accompanying customer care book.

For general assistance with your appliance or for information on Zanussi products please contact our Customer Services Department.

Customer Services Department  
 Major Appliances  
 Zanussi  
 Addington Way  
 Luton  
 Bedfordshire  
 LU4 9QQ  
 Tel: 08705 727 727 \*

\* calls to this number may be recorded for training purposes.



## GUARANTEE CONDITIONS

We Zanussi, undertake that if within 12 months of the date of the purchase this Zanussi built-in appliance or any part thereof is proved to be defective by reason only of faulty workmanship or materials, the company will, at our option repair or replace the same FREE OF ANY CHARGE for labour, materials or carriage on condition that:

- The appliance has been correctly installed and used only on the electrical supply stated on the rating plate.
- The appliance has been used for normal domestic purposes only, and in accordance with the manufacturer's operating and maintenance instructions.
- The appliance has not been serviced, maintained, repaired, taken apart or tampered with by any person not authorised by us.
- All service work under this guarantee must be undertaken by Zanussi Service Force Centre.
- Any appliance or defective part replaced shall become the property of this company.

Home visits are made between **8.30am and 5.30pm Monday to Friday**. Visits may be available outside these hours in which case a premium will be charged.

### EXCLUSIONS

**This Guarantee does not cover:**

- Damage or calls resulting from transportation, improper use or neglect, the replacement of any light bulbs or removable parts of glass or plastic.
- Costs incurred for calls to put right appliances improperly installed or calls to appliances outside the United Kingdom.
- Appliances found to be in use within a commercial environment, plus those which are the subject of rental agreements.
- Products of Zanussi manufacture which are not marked by Zanussi.

This guarantee is in addition to your statutory and legal rights.

### ZANUSSI EUROPEAN GUARANTEE

If you should move to another country within Europe then your guarantee moves with you to your new home subject to the following qualifications:

- The guarantee starts from the date you first purchased your product.
- The guarantee is for the same period and to the same extent for labour and parts as exists in the new country of use for this brand or range of products.
- This guarantee relates to you and cannot be transferred to another user.
- Your new home is within the European Community (EC) or European Free Trade Area.
- The product is installed and used in accordance with our instructions and is only used domestically, i.e. a normal household.

**Before you move please contact your nearest Customer Care Centre, listed below, to give them details of your new home. They will then ensure that the local Service Organisation is aware of your move and able to look after you and your appliances.**

France	Senlis	+33 (0)3 44 62 22 22
Germany	Nurnberg	+49 (0)911 323 2600
Italy	Pordenone	+39 (0)1678 47053
Sweden	Stockholm	+46 (0)20 78 77 50
UK	Luton	+44 (0)8705 727 727

# INSTALLATION INSTRUCTIONS



*It is dangerous to alter the specifications or attempt to modify this product in any way.*

## Technical Information

### DIMENSIONS

HEIGHT:	350mm
WIDTH:	598mm
DEPTH:	540mm

### WEIGHT

GROSS:	10,1 kg
NET:	8,9 kg

### ELECTRICAL SUPPLY:

Voltage (50Hz) 220-240 V

### POWER CONSUMPTION:

180W

### FAN MOTOR:

100W

### LAMP:

80W

### SUITABLE FOR INSTALLATION

#### ABOVE:

ELECTRIC HOB:	7KW (max)
GAS HOB:	10KW (max)
SLOT-IN GAS COOKER	13.5KW (max)
SLOT-IN ELECTRIC COOKER	12.4KW (max)



**Note: CE Marking certifies that this appliance complies with the requirements laid down in EEC directive 89:336. (Electromagnetic compatibility) and subsequent modifications and Low Voltage directive 72/23/E.**

## ELECTRICAL CONNECTIONS



*This appliance must be earthed*

### **Electrical Requirements**

Any permanent electrical installation must comply with the latest I.E.E. Regulations and local Electricity Board regulations. For your own safety this should be undertaken by a qualified electrician e.g. your local Electricity Board, or a contractor who is on the roll of the National Inspection Council for Electrical Installation Contracting (NICEIC).

### **Electrical Connection**

Before connecting to the mains supply ensure that the mains voltage corresponds to the voltage on the rating plate inside the cooker hood.

This appliance is fitted with a 3 core mains cable and must be permanently connected to the electricity supply via a double-pole switch having 3mm minimum contact gap on each pole. A Switched Fuse Connection Unit to BS1363 Part 4, fitted with a 3 Amp fuse, is a recommended mains supply connection accessory to ensure compliance with the Safety Requirements applicable to fixed wiring instructions.

This appliance conforms to BS 800: 1988 and EEC Directive No. 78 308 regarding suppression of radio and television interference.

# INSTALLING THE COOKER HOOD

**Please ensure that when the appliance is installed it is easily accessible to an engineer in the event of a breakdown.**



*All installations must comply with the local authorities requirements for the discharge of exhaust air.*

*Incorrect installation may affect the safety of this cooker hood.*

## Installation Requirements



*Before installation check the wall to which the cooker hood is to be fitted for electric cables, water pipes or gas.*

If it is necessary to fix the hood to a hollow construction plaster or partition board structure then it should be sufficiently reinforced to be quite rigid in the area of the cooker hood mounting brackets, and the appropriate rawl plugs used for this type of fixing (not supplied).

## Ducting

The ducting must be fire retardant 100mm (4ins) in diameter and the length should be no more than:

3 metres with one 90° bend

2 metres with two 90° bends

Bends of more than 90° will reduce the efficiency of the hood and reduce the airflow.



The clearance height between the inferior part of the cooker hood and the hob must be 650 mm (some models can be fitted at a lower height from the hob, please refer to the installation paragraph).

## Unpacking

The fittings supplied to install this cooker hood can be found with the instruction book inside the packaging.

## The fixing of the frontal panel to the visor:

- 1 Pull out the metal visor and, at the same time, unlock the lever on the left side of the hood.
- 2 Use the cardboard template when drilling the front panel. Fix the panel to the visor using the screws not supplied.

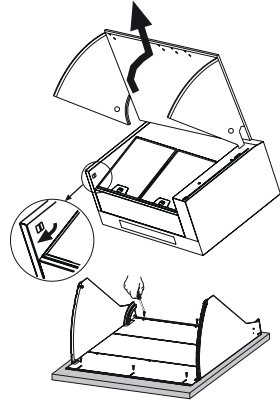

## Wall fitting

The cooker hood is fitted to the wall using the keyhole slots in the back of the hood.

- 1 Hood depth can vary from 275 to 360 mm.
- 2 Regulate the **Vx** screws when adjusting the brackets to the right depth.
- 3 When adjusting the lower part of the hood to the requested depth it is necessary to loose the screws of the metal distance piece and to move it as much as necessary.
- 4 Use the specific cardboard template when drilling the holes into the wall. Put the dowels into the holes and fix the two metal brackets using the four screws not supplied together with other accessories.
- 5 Use the specific cardboard template when drilling the side closets.

When the hood is used in ducting version it is necessary to remove the grid from the air outlet.

- 6 Hang the hood on the metal brackets.
- 7 Put back the visor again paying attention that the runners are put correctly into the proper places. Adjust the visor sliding by means of the two screws.
- 8 Regulating the **Vy** screws it is possible to align the hood height compared to the closets.
- 9 When necessary adjust again the hood depth.
- 10 Place the safety squares above the fixing brackets.
- 11 Mark the midpoint of the holes.
- 12 Drill the wall and fix the safety squares together with screws and dowels (supplied).

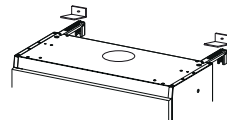
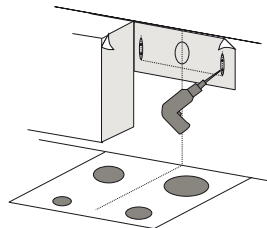
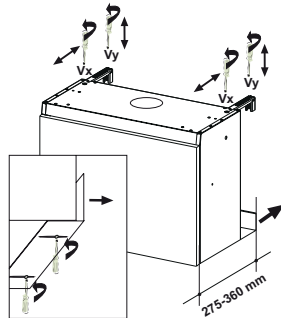

## Venting

The hood is more effective when used in the extraction setting (ducted to the outside).

Venting kits may be purchased through your retailer or DIY store, and must be ducted to an outside vent of 100mm (4") minimum.



*The ducting used must be manufactured from fire retardant material which should conform to the relevant British Standard or DIN4102-B1.*

When the hood is ducted externally the charcoal filter must be removed and the slider control must be in the ducting position.



## To Fit the Ducting

When installing the ducted version, connect the hood to the chimney using either a flexible or rigid pipe  $\varnothing 120$  mm, the choice of which is left to the installer.

- 1 Fix the pipe in position using sufficient pipe clamps (not supplied).
- 2 Remove any activated charcoal filters.

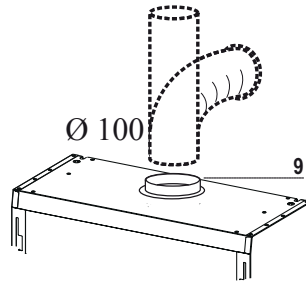

## Recirculation

The charcoal filter must be fitted for recirculation and the slider control must be in the recirculation position.



## Fitting the Cooker Hood to the Wall

- 1 Make sure that the hood body has been completely fixed.
- 2 Make sure that hood is equipped with charcoal filters.

The symbol  on the product or on its packaging indicates that this product may not be treated as household waste. Instead it shall be handed over to the applicable collection point for the recycling of electrical and electronic equipment. By ensuring this product is disposed of correctly, you will help prevent potential negative consequences for the environment and human health, which could otherwise be caused by inappropriate waste handling of this product. For more detailed information about recycling of this product, please contact your local city office, your household waste disposal service or the shop where you purchased the product.

# Service and Spare Parts

In the event of your appliance requiring service, or if you wish to purchase spare parts please contact your local Service Force Centre by telephoning:

**08705 929929**

Your telephone call will be automatically routed to the Service Force centre covering your post code area.

For the address of your local Service Force Centre and further information about Service Force, please visit the website at [www.serviceforce.co.uk](http://www.serviceforce.co.uk)

Before calling out an engineer, please ensure you read the details under the heading Something not working.

When you contact the Service Force Centre you will need to give the following details:

1. Your name, address and post code
2. Your telephone number
3. Clear and concise details of the fault
4. The model and serial number (found on the rating plate)
5. The purchase date

**Please note that a valid purchase receipt or guarantee documentation is required for in-guarantee service calls.**

For Customer Service in Ireland please contact us at the address below:

Zanussi  
Electrolux Group (Irl) Ltd  
Long Mile Road  
Dublin 12  
Republic of Ireland  
Tel: + 353 (0)1 4090751  
Email: [service.eid@electrolux.ie](mailto:service.eid@electrolux.ie)

# Customer Care Department

For general enquiries concerning your Zanussi appliance or for further information on Zanussi products please contact our Customer Care Department by letter or telephone at the address below or visit our website at [www.zanussi.co.uk](http://www.zanussi.co.uk)

Customer Services Department  
Major Appliances  
Zanussi  
Addington Way  
Luton  
Bedfordshire  
LU4 9QQ  
Tel: 08705 727 727 \*

\* calls to this number may be recorded for training purposes.

U kan toebehoren, verbruiksprodukten en onderdelen bestellen via onze webwinkel op:  
[www.zanussi.be](http://www.zanussi.be)

Vous pouvez commander des accessoires, consommables et pièces détachées via notre magasin online sur:  
[www.zanussi.be](http://www.zanussi.be)

Voor het on-line bestellen van accessoires, consumables en onderdelen gaat u naar de 'webwinkel' op:  
[www.zanussi.nl](http://www.zanussi.nl)

436005225\_01 - 101130