



CONTENTS

1. SAFETY INFORMATION.....	3
2. SAFETY INSTRUCTIONS.....	4
3. PRODUCT DESCRIPTION.....	7
4. CONTROL PANEL.....	8
5. BEFORE FIRST USE.....	10
6. DAILY USE.....	10
7. CLOCK FUNCTIONS.....	12
8. AUTOMATIC PROGRAMMES.....	14
9. USING THE ACCESSORIES.....	16
10. ADDITIONAL FUNCTIONS.....	18
11. HINTS AND TIPS.....	19
12. CARE AND CLEANING.....	34
13. TROUBLESHOOTING.....	37
14. ENERGY EFFICIENCY.....	39

FOR PERFECT RESULTS

Thank you for choosing this AEG product. We have created it to give you impeccable performance for many years, with innovative technologies that help make life simpler features you might not find on ordinary appliances. Please spend a few minutes reading to get the very best from it.

Visit our website for:



Get usage advice, brochures, trouble shooter, service information:
www.aeg.com



Register your product for better service:
www.registeraeg.com



Buy Accessories, Consumables and Original spare parts for your appliance:
www.aeg.com/shop

CUSTOMER CARE AND SERVICE

Always use original spare parts.

When contacting our Authorised Service Centre, ensure that you have the following data available: Model, PNC, Serial Number.

The information can be found on the rating plate.



Warning / Caution-Safety information



General information and tips



Environmental information

Subject to change without notice.

1. SAFETY INFORMATION

Before the installation and use of the appliance, carefully read the supplied instructions. The manufacturer is not responsible if an incorrect installation and use causes injuries and damages. Always keep the instructions with the appliance for future reference.

1.1 Children and vulnerable people safety

- This appliance can be used by children aged from 8 years and above and persons with reduced physical, sensory or mental capabilities or lack of experience and knowledge if they have been given supervision or instruction concerning use of the appliance in a safe way and understand the hazards involved.
- Do not let children play with the appliance.
- Keep all packaging away from children.
- Keep children and pets away from the appliance when it operates or when it cools down. Accessible parts are hot.
- If the appliance has a child safety device, we recommend you activate it.
- Cleaning and user maintenance shall not be made by children without supervision.
- Children of less than 3 years should be kept away unless continuously supervised.

1.2 General Safety

- Only a qualified person must install this appliance and replace the cable.
- Internally the appliance becomes hot when in operation. Do not touch the heating elements that are in the appliance. Always use oven gloves to remove or put in accessories or ovenware.
- Before maintenance cut the power supply.

- Ensure that the appliance is switched off before replacing the lamp to avoid the possibility of electric shock.
- Do not use a steam cleaner to clean the appliance.
- Do not use harsh abrasive cleaners or sharp metal scrapers to clean the glass door since they can scratch the surface, which may result in shattering of the glass.
- If the supply cord is damaged, it must be replaced by the manufacturer, its Authorised Service Centre or similarly qualified persons in order to avoid a hazard.
- Excess spillage must be removed before the pyrolytic cleaning. Remove all parts from the oven.
- To remove the shelf supports first pull the front of the shelf support and then the rear end away from the side walls. Install the shelf supports in the opposite sequence.
- Only use the core temperature sensor recommended for this appliance.

2. SAFETY INSTRUCTIONS

2.1 Installation



WARNING!

Only a qualified person must install this appliance.

- Remove all the packaging.
- Do not install or use a damaged appliance.
- Obey the installation instruction supplied with the appliance.
- Always be careful when you move the appliance because it is heavy. Always wear safety gloves.
- Do not pull the appliance by the handle.
- Keep the minimum distance from the other appliances and units.
- Make sure that the appliance is installed below and adjacent safe structures.
- The sides of the appliance must stay adjacent to appliances or to units with the same height.

2.2 Electrical connection



WARNING!

Risk of fire and electrical shock.

- All electrical connections should be made by a qualified electrician.
- The appliance must be earthed.
- Make sure that the electrical information on the rating plate agrees with the power supply. If not, contact an electrician.
- Always use a correctly installed shockproof socket.
- Do not use multi-plug adapters and extension cables.
- Make sure not to cause damage to the mains plug and to the mains cable. Should the mains cable need to be replaced, this must be carried out by our Authorised Service Centre.
- Do not let mains cables touch or come near the appliance door, especially when the door is hot.

- The shock protection of live and insulated parts must be fastened in such a way that it cannot be removed without tools.
 - Connect the mains plug to the mains socket only at the end of the installation. Make sure that there is access to the mains plug after the installation.
 - If the mains socket is loose, do not connect the mains plug.
 - Do not pull the mains cable to disconnect the appliance. Always pull the mains plug.
 - Use only correct isolation devices: line protecting cut-outs, fuses (screw type fuses removed from the holder), earth leakage trips and contactors.
 - The electrical installation must have an isolation device which lets you disconnect the appliance from the mains at all poles. The isolation device must have a contact opening width of minimum 3 mm.
 - This appliance complies with the E.E.C. Directives.
- Do not let sparks or open flames to come in contact with the appliance when you open the door.
 - Do not put flammable products or items that are wet with flammable products in, near or on the appliance.

**WARNING!**

Risk of damage to the appliance.

- To prevent damage or discoloration to the enamel:
 - do not put ovenware or other objects in the appliance directly on the bottom.
 - do not put aluminium foil directly on the bottom of the appliance.
 - do not put water directly into the hot appliance.
 - do not keep moist dishes and food in the appliance after you finish the cooking.
 - be careful when you remove or install the accessories.
- Discoloration of the enamel has no effect on the performance of the appliance. It is not a defect in the sense of the warranty law.
- Use a deep pan for moist cakes. Fruit juices cause stains that can be permanent.
- This appliance is for cooking purposes only. It must not be used for other purposes, for example room heating.
- Always cook with the oven door closed.

2.3 Use

**WARNING!**

Risk of injury, burns and electrical shock or explosion.

- Use this appliance in a household only.
- Do not change the specification of this appliance.
- Make sure that the ventilation openings are not blocked.
- Do not let the appliance stay unattended during operation.
- Deactivate the appliance after each use.
- Be careful when you open the appliance door while the appliance is in operation. Hot air can release.
- Do not operate the appliance with wet hands or when it has contact with water.
- Do not apply pressure on the open door.
- Do not use the appliance as a work surface or as a storage surface.
- Open the appliance door carefully. The use of ingredients with alcohol can cause a mixture of alcohol and air.

2.4 Care and cleaning

**WARNING!**

Risk of injury, fire, or damage to the appliance.

- Before maintenance, deactivate the appliance and disconnect the mains plug from the mains socket.
- Make sure the appliance is cold. There is the risk that the glass panels can break.
- Replace immediately the door glass panels when they are damaged. Contact the Service.
- Be careful when you remove the door from the appliance. The door is heavy!

- Clean regularly the appliance to prevent the deterioration of the surface material.
- Remaining fat or food in the appliance can cause fire.
- Clean the appliance with a moist soft cloth. Only use neutral detergents. Do not use abrasive products, abrasive cleaning pads, solvents or metal objects.
- If you use an oven spray, obey the safety instructions on the packaging.
- Do not clean the catalytic enamel (if applicable) with any kind of detergent.

2.5 Pyrolytic cleaning



Risk of Injury / Fires / Chemical Emissions (Fumes) in Pyrolytic Mode.

- Before carrying out a Pyrolytic self-cleaning function or the First Use please remove from the oven cavity:
 - any excess food residues, oil or grease spills / deposits.
 - any removable objects (including shelves, side rails etc., provided with the product) particularly any non-stick pots, pans, trays, utensils etc.
- Read carefully all the instructions for Pyrolytic cleaning.
- Keep children away from the appliance while the Pyrolytic cleaning is in operation.
The appliance becomes very hot and hot air is released from the front cooling vents.
- Pyrolytic cleaning is a high temperature operation that can release fumes from cooking residues and construction materials, as such consumers are strongly advised to:
 - provide good ventilation during and after each Pyrolytic cleaning.
 - provide good ventilation during and after the first use at maximum temperature operation.
- Unlike all humans, some birds and reptiles can be extremely sensitive to

potential fumes emitted during the cleaning process of all Pyrolytic Ovens.

- Remove any pets (especially birds) from the vicinity of the appliance location during and after the Pyrolytic cleaning and first use maximum temperature operation to a well ventilated area.
- Small pets can also be highly sensitive to the localized temperature changes in the vicinity of all Pyrolytic Ovens when the Pyrolytic self cleaning program is in operation.
- Non-stick surfaces on pots, pans, trays, utensils etc., can be damaged by the high temperature Pyrolytic cleaning operation of all Pyrolytic Ovens and can be also a source for low level harmful fumes.
- Fumes released from all Pyrolytic Ovens / Cooking Residues as described are not harmful to humans, including infants or persons with medical conditions.

2.6 Internal light

- The type of light bulb or halogen lamp used for this appliance is only for household appliances. Do not use it for house lighting.



WARNING!

Risk of electrical shock.

- Before replacing the lamp, disconnect the appliance from the power supply.
- Only use lamps with the same specifications.

2.7 Disposal



WARNING!

Risk of injury or suffocation.

- Disconnect the appliance from the mains supply.
- Cut off the mains cable and discard it.
- Remove the door catch to prevent children and pets to get closed in the appliance.

3. PRODUCT DESCRIPTION

3.1 General overview

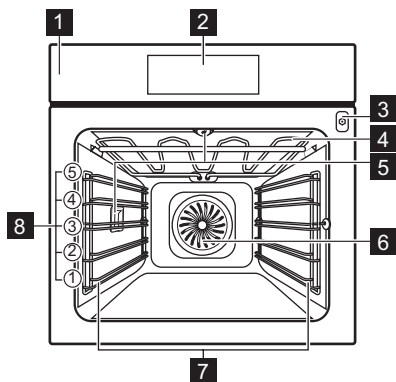

- 1 Control panel
- 2 Electronic programmer
- 3 Socket for the core temperature sensor
- 4 Heating element
- 5 Lamp
- 6 Fan
- 7 Shelf support, removable
- 8 Shelf positions

3.2 Accessories

Wire shelf

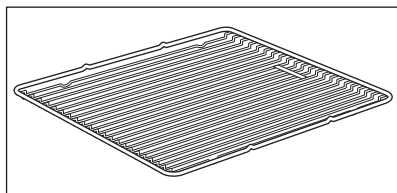

For cookware, cake tins, roasts.

Baking tray

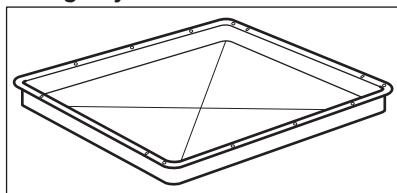

For cakes and biscuits.

Grill- / Roasting pan

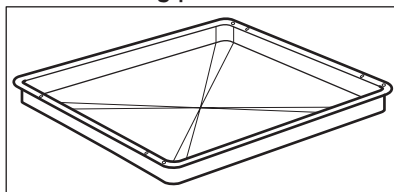

To bake and roast or as a pan to collect fat.

Core temperature sensor

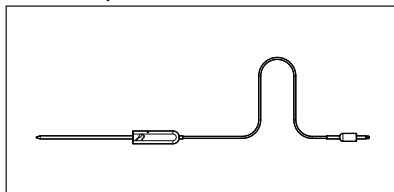





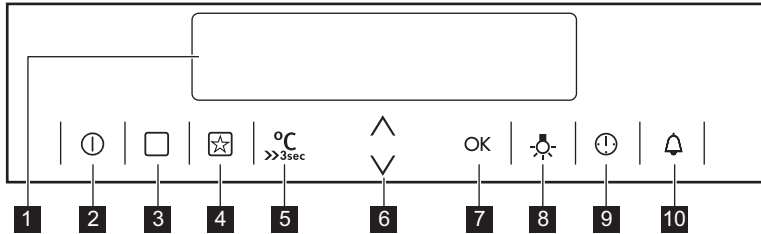

To measure how far the food is cooked.

4. CONTROL PANEL

4.1 Electronic programmer



Use the sensor fields to operate the appliance.

Sensor Field	Function	Description
1	-	DISPLAY Shows the current settings of the appliance.
2		ON / OFF To activate and deactivate the appliance.
3		OPTIONS To set an oven function or an automatic programme.
4		MY FAVOURITE PROGRAMME To store your favourite programme. Use it to have access to your favourite programme directly or when the appliance is deactivated.
5		TEMPERATURE / FAST HEAT UP To set and see the cavity temperature or the core temperature sensor temperature (if present). If you press and hold it for three seconds, it turns the Fast heat up function ON or OFF. Straight access to the temperature setting of the first oven function when the appliance is off.
6		UP, DOWN To move up or down in the menu.
7	OK	OK To confirm a selection or setting. To move down in the menu.
8		OVEN LIGHT To activate or deactivate the lamp.
9		CLOCK To set the clock functions.





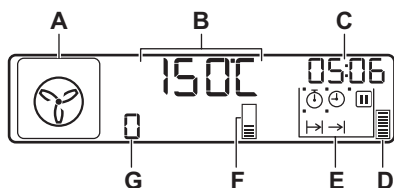



Sensor Field	Function	Description
10 	MINUTE MINDER	To set the Minute Minder.

4.2 Display



- A) Oven function symbol
- B) Temperature / time of day display
- C) Clock / Residual heat display / Minute Minder
- D) Residual heat indicator
- E) Indicators for the clock functions
- F) Heat-up indicator / Fast Heat Up indicator
- G) Number of an oven function / programme

Other indicators of the display:

Symbol	Name	Description
	Functions	You can choose an oven function.
	Automatic programme	You can choose an automatic programme.
	My favourite programme	The favourite programme operates.
kgr / gr	kg / g	An automatic programme with a weight input operates.
h / min	h / min	A clock function operates.
°C →	Temperature / Fast heat up	The function operates.
°C	Temperature	The current temperature is indicated.
	Temperature	You can change the temperature.
	Core temperature sensor	The core temperature sensor is in the core temperature sensor socket.
	Door lock	The door lock function operates.
	Light	You deactivated the light.
	Minute minder	The minute minder function operates.

4.3 Heat up indicator

If you activate an oven function, the bars

 come on in the display. The bars show that the temperature in the appliance increases or decreases.

When the appliance is at the set temperature, the bars go off the display.

5. BEFORE FIRST USE



WARNING!

Refer to Safety chapters.

5.1 Initial Cleaning

Remove all accessories and removable shelf supports from the appliance.









Refer to "Care and cleaning" chapter.

Clean the appliance before first use. Put the accessories and the removable shelf supports back to their initial position.

5.2 Setting the time

After the first connection to the mains, all symbols in the display are on for some seconds. For the subsequent few seconds the display shows the software version.

After the software version goes off, the display shows h and 12:00.

1. Touch  or  to set the hours.
2. Touch **OK** or .
3. Touch  or  to set the minutes.
4. Touch **OK** or .

The Temperature / Time display shows the new time.

5.3 Changing the time

You can change the time of day only when the appliance is off.

Touch .

 flashes in the display.

To set the new time of day, refer to "Setting the time".

6. DAILY USE



WARNING!



Refer to Safety chapters.













- **the manual mode**
- **automatic programmes**

6.1 Operating the appliance





To operate the appliance you can use:

6.2 Oven functions

Oven function	Application
 True Fan Cook- ing	To bake on up to 3 shelf positions at the same time and to dry food. Set the temperature 20 - 40 °C lower than for Conventional Cooking.
 Pizza Setting	To bake food on 1 shelf position for a more intensive browning and a crispy bottom. Set the temperature 20 - 40 °C lower than for Conventional Cooking.

Oven function	Application	
	Slow Cooking	To prepare tender, succulent roasts.
	Conventional Cooking	To bake and roast food on 1 shelf position.
	Frozen Foods	To make your convenience food like e.g. French Fries, Wedges, spring rolls crispy.
	Turbo Grilling	To roast larger meat joints or poultry with bones on 1 shelf position. Also to make gratins and to brown.
	Fast Grilling	To grill flat food in large quantities and to toast bread.
	Grilling	To grill flat food and to toast bread.
	Moist Fan Baking	To save energy when you bake and cook dry baked goods. Also to bake baked goods in tins on 1 shelf position. This function was used to define the energy efficiency class acc. EN50304.
	Keep Warm	To keep food warm.
	Defrost	To defrost frozen food.
	Bottom Heat	To bake cakes with crispy bottom and to preserve food.
	ECO Roasting	The ECO functions let you optimize the energy consumption during cooking. It is necessary to set the cooking time first. To get more information about the recommended settings, refer to the cooking tables with the equivalent function.
	Pyrolysis	To activate the automatic pyrolytic cleaning of the oven. This function burns off residual dirt in the oven.

6.3 Setting the oven function



1. Activate the appliance with  or . The display shows the set temperature, the symbol and the number of the oven function.
2. Touch  or  to set an oven function.

3. Touch **OK** or the appliance starts automatically after five seconds.





If you activate the appliance and do not set an oven function or programme, the appliance deactivates automatically after 20 seconds.

6.4 Changing the temperature

Touch  or  to change the temperature in steps of 5 °C. When the appliance is at the set temperature, an acoustic signal sounds three times and the Heat up indicator goes out.

6.5 Checking the temperature

You can see the temperature in the appliance when the function or programme operates.

1. Touch  .
The Temperature / Time display shows the temperature in the appliance.
2. Touch  to go back to the set temperature or the display shows it automatically after five seconds.

6.6 Fast heat up function





Do not put food in the oven when the Fast heat up function operates.

The Fast heat up function is not available with every oven function. An acoustic signal sounds if the Fast heat up function is not available for the set function if Faulty tone is activated in the "Settings menu".





The Fast heat up function decreases the heat up time.

To activate the Fast heat up function touch and hold  for more than three seconds.

If you activate the Fast heat up function, the bars on the display  flash one by one and   comes on to show that the function operates.

7. CLOCK FUNCTIONS



7.1 Clock functions table

Clock function	Application
 COUNT UP TIMER	To set the count up, which shows how long the appliance operates. This function has no effect on the operation of the appliance.
 TIME OF DAY	To show the time of day. To change the time of day, refer to "Setting the time".
 DURATION	To set how long the appliance operates.
 END	To set when the appliance deactivates. You can use Duration and End at the same time (Time delay) if you want the appliance to activate and deactivate automatically later.
 SET+GO	To start the appliance with necessary settings with only one touch of the sensor field any time later.



7.2 Count Up Timer

 The Count Up Timer is not activated if Duration and End are set.





The Count Up Timer starts to count when the appliance starts to heat.



1. To reset the Count Up Timer, touch  again and again until  flashes in the display.
2. Touch  until the display shows "00:00" and the Count Up Timer starts to count up again.

7.3 Setting the DURATION

1. Activate the appliance and set an oven function and temperature.
2. Touch  again and again until the display shows .

 flashes in the display.

3. Use  or  to set the minutes for DURATION.
4. Touch **OK** to confirm.
5. Use  or  to set the hours for DURATION.



 If you touch  or **OK** while you set the DURATION, the appliance switches to the setting of the END function.

6. When the set time ends, an acoustic signal sounds for two minutes.



 and time setting flash in the display. The appliance deactivates.

7. Touch a sensor field or open the oven door to stop the acoustic signal.
8. Deactivate the appliance.

7.4 Setting the END

1. Activate the appliance and set an oven function and temperature.
2. Touch  again and again until the display shows .

 flashes in the display.

3. Use  or  to set the END and **OK** or  to confirm. First you set the minutes and then the hours.



When the set time ends, an acoustic



signal sounds for two minutes.  symbol and the time setting flash in the display. The appliance deactivates.

4. Touch a sensor field or open the oven door to stop the acoustic signal.
5. Deactivate the appliance.

7.5 Setting the SET+GO

You can use the SET+GO function only when the DURATION is set.





1. Set an oven function (or a programme) and temperature (refer to "Setting the oven function" and "Changing the temperature").
2. Set the DURATION (refer to "Setting the DURATION").
3. Touch  again and again until  flashes in the display.
4. Touch **OK** to set the SET+GO function.

The display shows  and  with an indicator. This indicator shows which clock function is activated.

5. Touch a sensor field (apart from ON / OFF) to start the SET+GO function.

7.6 Setting the MINUTE MINDER

Use the MINUTE MINDER to set a countdown (maximum 23 h 59 min). This function has no effect on the operation of the oven. You can set the MINUTE MINDER at any time and also when the appliance is off.

1. Touch .
-  and "00" flash in the display.
2. Use  or  to set the MINUTE MINDER. First you set the seconds, then the minutes and the hours.
 3. Touch **OK** or the MINUTE MINDER starts automatically after five seconds.

When the set time ends, an acoustic signal sounds for two minutes and 00:00 and a 🔔 flash in the display.

4. Touch a sensor field or open the oven door to stop the acoustic signal.

7.7 Setting the Time delay function

The DURATION \rightarrow and END \rightarrow can be used at the same time, if the appliance is to be switched on and off automatically

later. In this case, first set the DURATION \rightarrow and then the END \rightarrow function (refer to "Setting the DURATION" and "Setting the END").



When the Time delay function is activated, the display shows a static symbol of the oven function, \rightarrow with a dot and \rightarrow . The dot shows which clock function is on in the Clock / residual heat display.

8. AUTOMATIC PROGRAMMES



WARNING!

Refer to Safety chapters.

There are 20 automatic programmes. Use an automatic programme or recipe

when you do not have the knowledge or experience on how to prepare a dish. The display shows the shelf position and the default cooking times for all automatic programmes.

8.1 Automatic programmes

Programme number	Programme name
1	BRAISED MEAT
2	ROAST PORK
3	ROAST VEAL
4	ROAST LAMB
5	ROAST GAME
6	CHICKEN, WHOLE
7	WHOLE FISH
8	PIZZA
9	QUICHE LORRAINE
10	LEMON SPONGE CAKE
11	CHEESE CAKE
12	ROLLS
13	FARMER BREAD
14	DOUGH PROVING
15	POTATO GRATIN
16	LASAGNE

Programme number	Programme name
17	CANNELLONI
18	CONVENIENCE CAKE
19	CONVENIENCE PIZZA
20	CONVENIENCE POTATO TYPES

8.2 Recipes online



You can find the recipes for the automatic programmes specified for this appliance on our website. To find the proper Recipe Book check the PNC number on the rating plate on the front frame of the appliance cavity.

8.3 Automatic programmes

1. Activate the appliance.

2. Touch .

The display shows , a symbol and the number of the automatic programme.

3. Touch  or  to choose the automatic programme.

4. Touch **OK** or wait five seconds until the appliance automatically starts to work.

5. When the set time ends, an acoustic signal sounds for two minutes. The symbol  flashes.

The appliance deactivates.



6. Touch a sensor field or open the door to stop the acoustic signal.

8.4 Automatic programmes with weight input

If you set the weight of the meat, the appliance calculates the roasting time.

1. Activate the appliance.



2. Touch .

3. Touch  or  to set the weight programme.

The display shows: the cooking time, the duration symbol , a default weight, a unit of measurement (kg, g).

4. Touch **OK** or the settings save automatically after five seconds.

The appliance activates.

5. You can change the default weight value with  or . Touch **OK**.

6. When the set time ends, an acoustic signal sounds for two minutes.  flashes.



The appliance deactivates.

7. Touch a sensor field or open the door to stop the acoustic signal.



8.5 Automatic programmes with the core temperature sensor



The core temperature of the food is default and fixed in programmes with the core temperature sensor. The programme ends when the appliance is at the set core temperature.

1. Activate the appliance.

2. Touch  again and again until the display shows .

3. Install the core temperature sensor. Refer to "Core temperature sensor".

4. Touch  or  to set the programme for the core temperature sensor.

The display shows the cooking time,  and .

5. Touch **OK** or the settings save automatically after five seconds.

When the set time ends, an acoustic signal sounds for two minutes.  flashes. The appliance deactivates.

6. Touch a sensor field or open the door to stop the acoustic signal.

9. USING THE ACCESSORIES



WARNING!

Refer to Safety chapters.

9.1 Core temperature sensor

There are two temperatures to be set: the oven temperature and the core temperature.

The core temperature sensor measures the core temperature of the meat. When the meat is at the set temperature, the appliance deactivates.



CAUTION!

Only use the core temperature sensor supplied or the correct replacement parts.



The core temperature sensor must stay in the meat and in the socket during the cooking.

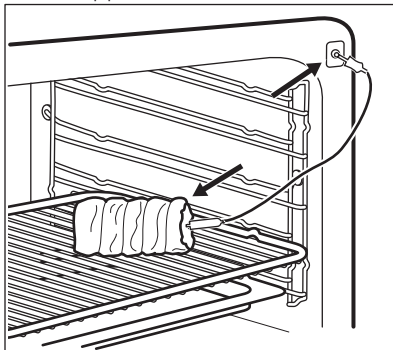

1. Activate the appliance.
2. Put the point of the core temperature sensor (with  on the handle) into the centre of the meat.
3. Put the plug of the core temperature sensor into the socket at the front of the appliance.







The display shows  flashing and the default set core temperature. The temperature is 60 °C for the first operation, and the last set value for each subsequent operation.



When you put the core temperature sensor into the socket, you cancel the settings for the clock functions.

4. Touch  or  to set the core temperature.
5. Touch **OK** or the settings save automatically after 5 seconds.



You can set the core temperature only when  flashes. If  is in the display but does not flash before you set the core temperature, touch  and  or  to set a new value.

6. Set the oven function and the oven temperature.

The display shows the current core temperature and the heat up symbol . While the appliance calculates the approximate duration time, the display shows the count up time. After the first calculation the display shows the approximate duration of the cooking time.

The appliance continues to calculate the duration during the cooking. The display updates at intervals with the new duration value.



When you cook with the core temperature sensor, you can change the temperature shown in the display. After you put the core temperature sensor in the socket and set an oven function and temperature, the display shows the current core temperature. Touch $^{\circ}\text{C}$ again and again to see three other temperatures:

- the set core temperature
- the current oven temperature
- the current core temperature.

When the meat is at the set core temperature, an acoustic signal sounds for two minutes and the value of the core temperature and  flash. The appliance deactivates.

7. Touch a sensor field to deactivate the acoustic signal.
8. Remove the core temperature sensor from the socket and remove the meat from the appliance.



WARNING!

Be careful when you remove the core temperature sensor. It is hot. There is a risk of burns.

9.2 Inserting the accessories

Wire shelf:

Push the shelf between the guide bars of the shelf support and make sure that the feet point down.

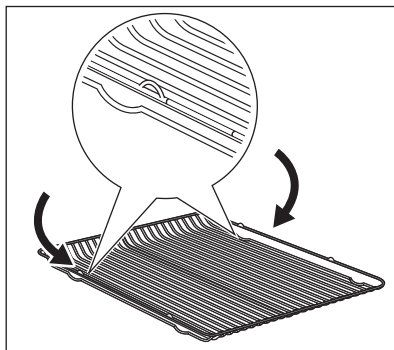

Deep pan:

Push the deep pan between the guide bars of the shelf support.

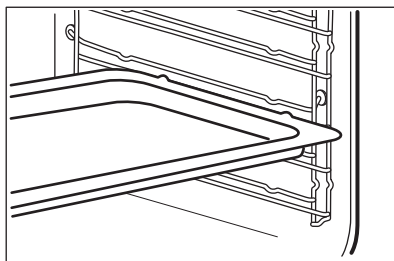

Wire shelf and the deep pan together:

Push the deep pan between the guide bars of the shelf support and the wire shelf on the guide bars above.

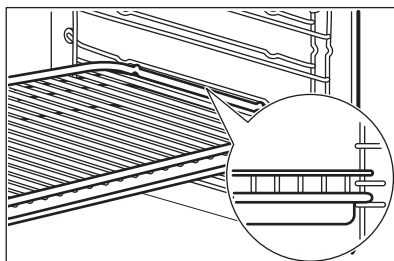



- All accessories have small indentations at the top of the right and left side to increase safety. The indentations are also anti-tip devices.
- The high rim around the shelf is a device which prevents cookware from slipping.

10. ADDITIONAL FUNCTIONS

10.1 Using My Favourite Programme function

Use this function to save your favourite temperature and time settings for an oven function or programme.

1. Set the temperature and time for an oven function or programme.
 2. Touch and hold  for more than three seconds. An acoustic signal sounds.
 3. Deactivate the appliance.
- **To activate the function** touch . The appliance activates your favourite programme.



 When the function operates, you can change the time and temperature.

- **To deactivate the function** touch . The appliance deactivates your favourite programme.

10.2 Using the Child Lock

The Child Lock prevents an accidental operation of the appliance.

 If the Pyrolysis function operates, the door is locked. A message comes on in the display when you touch a sensor field.



1. To activate the function deactivate the appliance with . Do not set an oven function.
2. Touch and hold  and  at the same time for 2 seconds. An acoustic signal sounds.

SAFE comes on in the display. To deactivate the Child Lock function repeat step 2.

10.3 Using the Function Lock

You can activate the function only when the appliance operates.

The Function Lock prevents an accidental change of the oven function.

1. To activate the function activate the appliance.
2. Activate an oven function or setting.
3. Touch and hold  and  at the same time for 2 seconds.

An acoustic signal sounds. Loc comes on in the display. To deactivate the Function Lock repeat step 3.

 If the Pyrolysis function operates, the door is locked. A message comes on in the display when you touch a sensor field.

 You can deactivate the appliance when the Function Lock is on. When you deactivate the appliance, the Function Lock deactivates.

10.4 Using the settings menu





You can set the settings menu only when the appliance is deactivated.

The settings menu lets you activate or deactivate functions in the main menu. The display shows SET and the number of the setting.

	Description	Value to set
1	SET + GO	ON / OFF
2	RESIDUAL HEAT INDICATOR	ON / OFF
3	CLEANING REMINDER	ON / OFF

	Description	Value to set
4	KEY TONE ¹⁾	CLICK / BEEP / OFF
5	FAULTY TONE	ON / OFF
6	SERVICE MENU	-
7	RESTORE SETTINGS	ON / OFF

¹⁾ It is not possible to deactivate the tone of the ON / OFF sensor field.

- When the appliance is deactivated, touch and hold  for three seconds. The display shows SET1 and "1" flashes.
- Touch  or  to set the setting.
- Touch **OK**.
- Touch  or  to change the value of the setting.
- Touch **OK**.

10.5 Automatic Switch-off

For safety reasons the appliance deactivates automatically after some time if an oven function operates and you do not change any settings.

Temperature (°C)	Switch-off time (h)
30 - 115	12.5
120 - 195	8.5
200 - 245	5.5
250 - maximum	1.5

After the Automatic switch-off, touch a sensor field to operate the appliance again.

-  The Automatic switch-off does not work with the functions: core temperature sensor, Light, Slow Cooking, Duration, End, Time delay.

10.6 Brightness of the display

There are two modes of display brightness:

- Night brightness - when the appliance is deactivated, the brightness of the display is lower between 10 PM and 6 AM.
- Day brightness:
 - when the appliance is activated.
 - if you touch a sensor field during the night brightness (apart from ON / OFF), the display goes back to the day brightness mode for the next 10 seconds.
 - if the appliance is deactivated and you set the Minute Minder. When the Minute Minder function ends, the display goes back to the night brightness.

10.7 Cooling fan

When the appliance operates, the cooling fan activates automatically to keep the surfaces of the appliance cool. If you deactivate the appliance, the cooling fan can continue to operate until the appliance cools down.

11. HINTS AND TIPS



WARNING!
Refer to Safety chapters.



The temperature and baking times in the tables are guidelines only. They depend on the recipes and the quality and quantity of the ingredients used.

11.1 Inner side of the door

In some models, on the inner side of the door you can find:

- the numbers of the shelf positions.
- information about the oven functions, recommended shelf positions and temperatures for typical dishes.

11.2 Baking

- Your oven can bake or roast differently to the appliance you had before. Adapt your usual settings (temperature, cooking times) and shelf positions to the values in the tables.

- The manufacturer recommends that you use the lower temperature the first time.
- If you cannot find the settings for a special recipe, look for the one that is almost the same.
- You can extend baking times by 10 – 15 minutes if you bake cakes on more than one shelf position.
- Cakes and pastries at different heights do not always brown equally at first. If this occurs, do not change the temperature setting. The differences equalize during the baking procedure.
- With longer baking times, you can deactivate the oven approximately 10 minutes before the end of the baking time and then use the residual heat.

When you cook frozen food, the trays in the oven can twist during baking. When the trays become cold again, the distortions are gone.

11.3 Tips on baking

Baking results	Possible cause	Remedy
The bottom of the cake is not browned sufficiently.	The shelf position is incorrect.	Put the cake on a lower shelf.
The cake sinks and becomes soggy, lumpy or streaky.	The oven temperature is too high.	The next time you bake, set a slightly lower oven temperature.
The cake sinks and becomes soggy, lumpy or streaky.	The baking time is too short.	Set a longer baking time. You cannot decrease baking times by setting higher temperatures.
The cake sinks and becomes soggy, lumpy or streaky.	There is too much liquid in the mixture.	Use less liquid. Be careful with mixing times, especially if you use a mixing machine.
The cake is too dry.	The oven temperature is too low.	The next time you bake, set a higher oven temperature.
The cake is too dry.	The baking time is too long.	The next time you bake, set a shorter baking time.
The cake browns unevenly.	The oven temperature is too high and the baking time is too short.	Set a lower oven temperature and a longer baking time.

Baking results	Possible cause	Remedy
The cake browns unevenly.	The mixture is unevenly distributed.	Spread the mixture evenly on the baking tray.
The cake is not ready in the baking time given.	The oven temperature is too low.	The next time you bake, set a slightly higher oven temperature.

11.4 Baking on one level:

Baking in tins

Food	Function	Temperature (°C)	Time (min)	Shelf position
Ring cake / Brioche	True Fan Cooking	150 - 160	50 - 70	1
Madeira cake / Fruit cakes	True Fan Cooking	140 - 160	70 - 90	1
Fatless sponge cake / Fatless sponge cake	True Fan Cooking	140 - 150	35 - 50	2
Fatless sponge cake / Fatless sponge cake	Conventional Cooking	160	35 - 50	2
Flan base - short pastry	True Fan Cooking	170 - 180 ¹⁾	10 - 25	2
Flan base - sponge mixture	True Fan Cooking	150 - 170	20 - 25	2
Apple pie / Apple pie (2 tins Ø20 cm, diagonally off set)	True Fan Cooking	160	60 - 90	2
Apple pie / Apple pie (2 tins Ø20 cm, diagonally off set)	Conventional Cooking	180	70 - 90	1
Cheesecake	Conventional Cooking	170 - 190	60 - 90	1

¹⁾ Preheat the oven.

Cakes / pastries / breads on baking trays

Food	Function	Temperature (°C)	Time (min)	Shelf position
Plaited bread / Bread crown	Conventional Cooking	170 - 190	30 - 40	3
Christmas stolen	Conventional Cooking	160 - 180 ¹⁾	50 - 70	2
Bread (rye bread): 1. First part of baking procedure. 2. Second part of baking procedure.	Conventional Cooking	1. 230 ¹⁾ 2. 160 - 180	1. 20 2. 30 - 60	1
Cream puffs / Eclairs	Conventional Cooking	190 - 210 ¹⁾	20 - 35	3
Swiss roll	Conventional Cooking	180 - 200 ¹⁾	10 - 20	3
Cake with crumble topping (dry)	True Fan Cooking	150 - 160	20 - 40	3
Buttered almond cake / Sugar cakes	Conventional Cooking	190 - 210 ¹⁾	20 - 30	3
Fruit flans (made with yeast dough / sponge mixture) ²⁾	True Fan Cooking	150	35 - 55	3
Fruit flans (made with yeast dough / sponge mixture) ²⁾	Conventional Cooking	170	35 - 55	3
Fruit flans made with short pastry	True Fan Cooking	160 - 170	40 - 80	3
Yeast cakes with delicate toppings (e.g. quark, cream, custard)	Conventional Cooking	160 - 180 ¹⁾	40 - 80	3

¹⁾ Preheat the oven.

²⁾ Use a deep pan.

Biscuits

Food	Function	Temperature (°C)	Time (min)	Shelf position
Short pastry biscuits	True Fan Cooking	150 - 160	10 - 20	3
Short bread / Short bread / Pastry stripes	True Fan Cooking	140	20 - 35	3
Short bread / Short bread / Pastry stripes	Conventional Cooking	160 ¹⁾	20 - 30	3
Biscuits made with sponge mixture	True Fan Cooking	150 - 160	15 - 20	3
Pastries made with egg white / Meringues	True Fan Cooking	80 - 100	120 - 150	3
Macaroons	True Fan Cooking	100 - 120	30 - 50	3
Biscuits made with yeast dough	True Fan Cooking	150 - 160	20 - 40	3
Puff pastries	True Fan Cooking	170 - 180 ¹⁾	20 - 30	3
Rolls	True Fan Cooking	160 ¹⁾	10 - 25	3
Rolls	Conventional Cooking	190 - 210 ¹⁾	10 - 25	3
Small cakes / Small cakes (20 per tray)	True Fan Cooking	150 ¹⁾	20 - 35	3
Small cakes / Small cakes (20 per tray)	Conventional Cooking	170 ¹⁾	20 - 30	3

¹⁾ Preheat the oven.

11.5 Bakes and gratins

Food	Function	Temperature (°C)	Time (min)	Shelf position
Pasta bake	Conventional Cooking	180 - 200	45 - 60	1

Food	Function	Temperature (°C)	Time (min)	Shelf position
Lasagne	Conventional Cooking	180 - 200	25 - 40	1
Vegetables au gratin ¹⁾	Turbo Grilling	160 - 170	15 - 30	1
Baguettes topped with melted cheese	True Fan Cooking	160 - 170	15 - 30	1
Sweet bakes	Conventional Cooking	180 - 200	40 - 60	1
Fish bakes	Conventional Cooking	180 - 200	30 - 60	1
Stuffed vegetables	True Fan Cooking	160 - 170	30 - 60	1

¹⁾ Preheat the oven.

11.6 Moist Fan Baking

Food Type of food	Temperature (°C)	Time (min)	Shelf position
Pasta bake	180 - 200	45 - 60	2
Lasagne	180 - 200	45 - 60	2
Potato gratin	190 - 210	55 - 80	2
Sweet dishes	180 - 200	45 - 60	2
Ring cake or brioche	160 - 170	50 - 70	1
Plaited bread / bread crown	170 - 190	40 - 50	2
Cake with crumble topping (dry)	160 - 170	20 - 40	3
Biscuits made with yeast dough	160 - 170	20 - 40	2

11.7 Multilevel Baking

Use the function True Fan Cooking.

Cakes / pastries / breads on baking trays

Food	Temperature (°C)	Time (min)	Shelf position	
			2 positions	3 positions
Cream puffs / Eclairs	160 - 180 ¹⁾	25 - 45	1 / 4	-
Dry streusel cake	150 - 160	30 - 45	1 / 4	-

¹⁾ Preheat the oven.

Biscuits / small cakes / small cakes / pastries / rolls

Food	Temperature (°C)	Time (min)	Shelf position	
			2 positions	3 positions
Short pastry biscuits	150 - 160	20 - 40	1 / 4	1 / 3 / 5
Short bread / Short bread / Pastry Stripes	140	25 - 45	1 / 4	1 / 3 / 5
Biscuits made with sponge mixture	160 - 170	25 - 40	1 / 4	-
Biscuits made with egg white, meringues	80 - 100	130 - 170	1 / 4	-
Macaroons	100 - 120	40 - 80	1 / 4	-
Biscuits made with yeast dough	160 - 170	30 - 60	1 / 4	-
Puff pastries	170 - 180 ¹⁾	30 - 50	1 / 4	-
Rolls	180	20 - 30	1 / 4	-
Small cakes / Small cakes (20 per tray)	150 ¹⁾	23 - 40	1 / 4	-

¹⁾ Preheat the oven.

11.8 Slow Cooking

Use this function to prepare lean, tender pieces of meat and fish with core temperatures no more than 65 °C. This function is not applicable to such recipes as pot roast or fatty roast pork. You can use the core temperature sensor to guarantee that the meat has the correct

core temperature (see the table for the core temperature sensor).

In the first 10 minutes you can set an oven temperature between 80 °C and 150 °C. The default is 90 °C. After the temperature is set, the oven continues to cook at 80 °C. Do not use this function for poultry.



Always cook without a lid when you use this function.

1. Sear the meat in a pan on the hob on a very high setting for 1 - 2 minutes on each side.
2. Put the meat together with the hot roasting pan into the oven on the wire shelf.
3. Put the core temperature sensor into the meat.
4. Select the function Slow Cooking and set the correct end core temperature.

Food	Quantity	Temperature (°C)	Time (min)	Shelf position
Roast beef	1000 - 1500 g	120	120 - 150	1
Fillet of beef	1000 - 1500 g	120	90 - 150	3
Roast veal	1000 - 1500 g	120	120 - 150	1
Steaks	200 - 300 g	120	20 - 40	3

11.9 Pizza Setting

Food	Temperature (°C)	Time (min)	Shelf position
Pizza (thin crust)	200 - 230 ¹⁾²⁾	15 - 20	2
Pizza (with a lot of topping)	180 - 200	20 - 30	2
Tarts	180 - 200	40 - 55	1
Spinach flan	160 - 180	45 - 60	1
Quiche Lorraine	170 - 190	45 - 55	1
Swiss Flan	170 - 190	45 - 55	1
Cheesecake	140 - 160	60 - 90	1
Apple cake, covered	150 - 170	50 - 60	1
Vegetable pie	160 - 180	50 - 60	1
Unleavened bread	230 - 250 ¹⁾	10 - 20	2
Puff pastry flan	160 - 180 ¹⁾	45 - 55	2
Flammekuchen (Pizza-like dish from Alsace)	230 - 250 ¹⁾	12 - 20	2
Piroggen (Russian version of calzone)	180 - 200 ¹⁾	15 - 25	2

1) Preheat the oven.

2) Use a deep pan.

11.10 Roasting

- Use heat-resistant ovenware to roast (refer to the instructions of the manufacturer).
- You can roast large roasting joints directly in the deep pan (if present) or on the wire shelf above the deep pan.
- Roast lean meats in the roasting tin with the lid. This keeps the meat more succulent.
- All types of meat that can be browned or have crackling can be roasted in the roasting tin without the lid.
- We recommend that you cook meat and fish weighing 1 kg and above in the appliance.
- To prevent the meat juices or fat from burning onto the pan, put some liquid into the deep pan.
- If necessary, turn the roast (after 1/2 - 2/3 of the cooking time).
- Baste large roasts and poultry with their juices several times during roasting. This gives better roasting results.
- You can deactivate the appliance approximately 10 minutes before the end of the roasting time, and use the residual heat.

11.11 Roasting tables

Beef

Food	Quantity	Function	Temperature (°C)	Time (min)	Shelf position
Pot roast	1 - 1.5 kg	Conventional Cooking	230	120 - 150	1
Roast beef or fillet: rare	per cm of thickness	Turbo Grilling	190 - 200 ¹⁾	5 - 6	1
Roast beef or fillet: medium	per cm of thickness	Turbo Grilling	180 - 190 ¹⁾	6 - 8	1
Roast beef or fillet: well done	per cm of thickness	Turbo Grilling	170 - 180 ¹⁾	8 - 10	1

¹⁾ Preheat the oven.

Pork

Food	Quantity	Function	Temperature (°C)	Time (min)	Shelf position
Shoulder / Neck / Ham joint	1 - 1.5 kg	Turbo Grilling	160 - 180	90 - 120	1
Chop / Spare rib	1 - 1.5 kg	Turbo Grilling	170 - 180	60 - 90	1
Meatloaf	750 g - 1 kg	Turbo Grilling	160 - 170	50 - 60	1
Pork knuckle (precooked)	750 g - 1 kg	Turbo Grilling	150 - 170	90 - 120	1

Veal

Food	Quantity (kg)	Function	Temperature (°C)	Time (min)	Shelf position
Roast veal	1	Turbo Grilling	160 - 180	90 - 120	1
Knuckle of veal	1.5 - 2	Turbo Grilling	160 - 180	120 - 150	1

Lamb

Food	Quantity (kg)	Function	Temperature (°C)	Time (min)	Shelf position
Leg of lamb / Roast lamb	1 - 1.5	Turbo Grilling	150 - 170	100 - 120	1
Saddle of lamb	1 - 1.5	Turbo Grilling	160 - 180	40 - 60	1

Game

Food	Quantity	Function	Temperature (°C)	Time (min)	Shelf position
Saddle / Leg of hare	up to 1 kg	Conventional Cooking	230 ¹⁾	30 - 40	1
Saddle of venison	1.5 - 2 kg	Conventional Cooking	210 - 220	35 - 40	1
Haunch of venison	1.5 - 2 kg	Conventional Cooking	180 - 200	60 - 90	1

1) Preheat the oven.

Poultry

Food	Quantity	Function	Temperature (°C)	Time (min)	Shelf position
Poultry portions	200 - 250 g each	Turbo Grilling	200 - 220	30 - 50	1
Half chicken	400 - 500 g each	Turbo Grilling	190 - 210	35 - 50	1
Chicken, poulard	1 - 1.5 kg	Turbo Grilling	190 - 210	50 - 70	1
Duck	1.5 - 2 kg	Turbo Grilling	180 - 200	80 - 100	1
Goose	3.5 - 5 kg	Turbo Grilling	160 - 180	120 - 180	1

Food	Quantity	Function	Temperature (°C)	Time (min)	Shelf position
Turkey	2.5 - 3.5 kg	Turbo Grilling	160 - 180	120 - 150	1
Turkey	4 - 6 kg	Turbo Grilling	140 - 160	150 - 240	1

Fish (steamed)

Food	Quantity (kg)	Function	Temperature (°C)	Time (min)	Shelf position
Whole fish	1 - 1.5	Conventional Cooking	210 - 220	40 - 60	1

11.12 Grilling

- Always grill with the maximum temperature setting.
- Set the shelf into the shelf position as recommended in the grilling table.
- Always set the pan to collect the fat into the first shelf position.

- Grill only flat pieces of meat or fish.
- Always preheat the empty oven with the grill functions for 5 minutes.



CAUTION!

Always grill with the oven door closed.

Grilling

Food	Temperature (°C)	Time (min)		Shelf position
		1st side	2nd side	
Roast beef	210 - 230	30 - 40	30 - 40	2
Filet of beef	230	20 - 30	20 - 30	3
Back of pork	210 - 230	30 - 40	30 - 40	2
Back of veal	210 - 230	30 - 40	30 - 40	2
Back of lamb	210 - 230	25 - 35	20 - 25	3
Whole Fish, 500 - 1000 g	210 - 230	15 - 30	15 - 30	3 / 4

Fast Grilling

Food	Time (min)		Shelf position
	1st side	2nd side	
Burgers / Burgers	8 - 10	6 - 8	4
Pork fillet	10 - 12	6 - 10	4
Sausages	10 - 12	6 - 8	4
Fillet / Veal steaks	7 - 10	6 - 8	4

Food	Time (min)		Shelf position
	1st side	2nd side	
Toast / Toast ¹⁾	1 - 3	1 - 3	5
Toast with topping	6 - 8	-	4

¹⁾ Preheat the oven.

11.13 Frozen foods

Food	Temperature (°C)	Time (min)	Shelf position
Pizza, frozen	200 - 220	15 - 25	2
Pizza American, frozen	190 - 210	20 - 25	2
Pizza, chilled	210 - 230	13 - 25	2
Pizza Snacks, frozen	180 - 200	15 - 30	2
French Fries, thin	200 - 220	20 - 30	3
French Fries, thick	200 - 220	25 - 35	3
Wedges / Croquettes	220 - 230	20 - 35	3
Hash Browns	210 - 230	20 - 30	3
Lasagne / Cannelloni, fresh	170 - 190	35 - 45	2
Lasagne / Cannelloni, frozen	160 - 180	40 - 60	2
Oven baked cheese	170 - 190	20 - 30	3
Chicken Wings	190 - 210	20 - 30	2

Frozen ready meals

Food	Function	Temperature (°C)	Time (min)	Shelf position
Frozen pizza	Conventional Cooking	as per manufacturer's instructions	as per manufacturer's instructions	3
French fries ¹⁾ (300 - 600 g)	Conventional Cooking or Turbo Grilling	200 - 220	as per manufacturer's instructions	3
Baguettes	Conventional Cooking	as per manufacturer's instructions	as per manufacturer's instructions	3

Food	Function	Temperature (°C)	Time (min)	Shelf position
Fruit flans	Conventional Cooking	as per manufacturer's instructions	as per manufacturer's instructions	3

1) Turn the French fries 2 or 3 times during cooking.

11.14 Defrost

- Remove the food packaging and put the food on a plate.
- Use the first shelf position from the bottom.

- Do not cover the food with a bowl or a plate, as this can extend the defrost time.

Food	Quantity	Defrosting time (min)	Further defrosting time (min)	Comments
Chicken	1 kg	100 - 140	20 - 30	Put the chicken on an upturned saucer in a big plate. Turn halfway through.
Meat	1 kg	100 - 140	20 - 30	Turn halfway through.
Meat	500 g	90 - 120	20 - 30	Turn halfway through.
Trout	150 g	25 - 35	10 - 15	-
Strawberries	300 g	30 - 40	10 - 20	-
Butter	250 g	30 - 40	10 - 15	-
Cream	2 x 200 g	80 - 100	10 - 15	Whip the cream when still slightly frozen in places.
Gateau	1.4 kg	60	60	-

11.15 Preserving - Bottom Heat

- Use only preserve jars of the same dimensions available on the market.
- Do not use jars with twist-off and bayonet type lids or metal tins.
- Use the first shelf from the bottom for this function.
- Put no more than six one-litre preserve jars on the baking tray.
- Fill the jars equally and close with a clamp.
- The jars cannot touch each other.
- Put approximately 1/2 litre of water into the baking tray to give sufficient moisture in the oven.
- When the liquid in the jars starts to simmer (after approximately 35 - 60 minutes with one-litre jars), stop the oven or decrease the temperature to 100 °C (see the table).

Soft fruit

Food	Temperature (°C)	Cooking time until simmering (min)	Continue to cook at 100 °C (min)
Strawberries / Blueberries / Raspberries / Ripe gooseberries	160 - 170	35 - 45	-

Stone fruit

Food	Temperature (°C)	Cooking time until simmering (min)	Continue to cook at 100 °C (min)
Pears / Quinces / Plums	160 - 170	35 - 45	10 - 15

Vegetables

Food	Temperature (°C)	Cooking time until simmering (min)	Continue to cook at 100 °C (min)
Carrots ¹⁾	160 - 170	50 - 60	5 - 10
Cucumbers	160 - 170	50 - 60	-
Mixed pickles	160 - 170	50 - 60	5 - 10
Kohlrabi / Peas / Asparagus	160 - 170	50 - 60	15 - 20

¹⁾ Leave standing in the oven after it is deactivated.

11.16 Drying - True Fan Cooking

- Cover trays with grease proof paper or baking parchment.

- For a better result, stop the oven halfway through the drying time, open the door and let it cool down for one night to complete the drying.

Vegetables

Food	Temperature (°C)	Time (h)	Shelf position	
			1 position	2 positions
Beans	60 - 70	6 - 8	3	1 / 4
Peppers	60 - 70	5 - 6	3	1 / 4
Vegetables for sour	60 - 70	5 - 6	3	1 / 4
Mushrooms	50 - 60	6 - 8	3	1 / 4
Herbs	40 - 50	2 - 3	3	1 / 4

Fruit

Food	Temperature (°C)	Time (h)	Shelf position	
			1 position	2 positions
Plums	60 - 70	8 - 10	3	1 / 4
Apricots	60 - 70	8 - 10	3	1 / 4
Apple slices	60 - 70	6 - 8	3	1 / 4
Pears	60 - 70	6 - 9	3	1 / 4

11.17 Core temperature sensor table**Beef**

Food	Food core temperature (°C)
Rib / Fillet steak: rare	45 - 50
Rib / Fillet steak: medium	60 - 65
Rib / Fillet steak: well done	70 - 75

Pork

Food	Food core temperature (°C)
Shoulder / Ham / Neck joint of pork	80 - 82
Chop (saddle) / Smoked pork loin	75 - 80
Meatloaf	75 - 80

Veal

Food	Food core temperature (°C)
Roast veal	75 - 80
Knuckle of veal	85 - 90

Mutton / lamb

Food	Food core temperature (°C)
Leg of mutton	80 - 85
Saddle of mutton	80 - 85
Roast lamb / Leg of lamb	70 - 75

Game

Food	Food core temperature (°C)
Saddle of hare	70 - 75
Leg of hare	70 - 75

Food	Food core temperature (°C)
Whole hare	70 - 75
Saddle of venison	70 - 75
Leg of venison	70 - 75

Fish

Food	Food core temperature (°C)
Salmon	65 - 70
Trouts	65 - 70

12. CARE AND CLEANING



WARNING!

Refer to Safety chapters.

12.1 Notes on cleaning

- Clean the front of the appliance with a soft cloth with warm water and a cleaning agent.
- To clean metal surfaces, use a usual cleaning agent.
- Clean the appliance interior after each use. Fat accumulation or other food remains may result in a fire. The risk is higher for the grill pan.
- Clean stubborn dirt with a special oven cleaner.
- Clean all accessories after each use and let them dry. Use a soft cloth with warm water and a cleaning agent.
- If you have nonstick accessories, do not clean them using aggressive agents, sharp-edged objects or a dishwasher. It can cause damage to the nonstick coating.

12.2 Removing the shelf supports

To clean the oven, remove the shelf supports.

1. Pull the front of the shelf support away from the side wall.

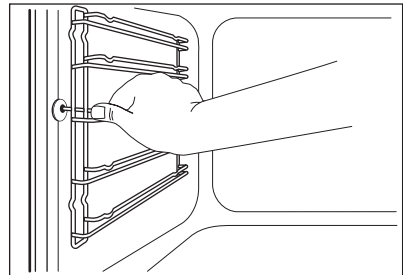

2. Pull the rear end of the shelf support away from the side wall and remove it.

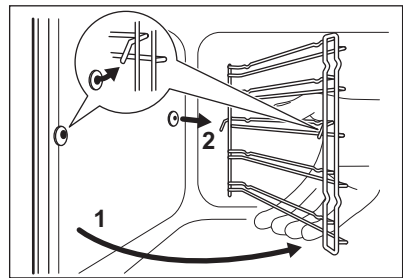

Install the shelf supports in the opposite sequence.

12.3 Pyrolysis



CAUTION!

Remove all accessories and removable shelf supports.

**The pyrolytic cleaning procedure cannot start:**



- if you did not remove the core temperature sensor plug from the socket. In some models, the display shows "C2" when this error occurs.
- if you did not fully close the oven door. In some models, the display shows "C3" when this error occurs.

**CAUTION!**

If there are other appliances installed in the same cabinet, do not use them at the same time as the Pyrolysis function. It can cause damage to the appliance.

During the pyrolytic cleaning the door is locked. The symbol  and the bars of the heat indicator come up, until the door unlocks. The door unlocks when the temperature inside the oven is under safety conditions and the pyrolytic cleaning finishes.

During the pyrolytic cleaning the lamp is deactivated.

1. Remove the worst dirt manually.
2. Clean the inner side of the door with hot water, so that the residues do not burn from the hot air.
3. Activate the appliance.
4. Set the Pyrolysis function (refer to "Oven functions").
5. Touch  or  to set the duration of the cleaning procedure:

Option	Description
1	1:00 h for a low degree of dirt
2	1:30 h for a usual degree of dirt

3

2:30 h for a high degree of dirt

You can use the End function to delay the start of the cleaning procedure.

6. Touch **OK** to activate the Pyrolysis function.

12.4 Cleaning reminder

To remind you that the pyrolytic cleaning is necessary, the cleaning reminder symbol  flashes in the display after each deactivation of the appliance for the next 10 seconds.

**The cleaning reminder goes out:**

- after the end of the pyrolytic cleaning.
- when you deactivate it in the basic settings. Refer to "Using the settings menu".

12.5 Removing and installing the door

You can remove the door and the internal glass panels to clean it. The number of glass panels is different for different models.

**WARNING!**

Be careful when you remove the door from the appliance. The door is heavy.

1. Open the door fully.
2. Fully press the clamping levers (A) on the two door hinges.

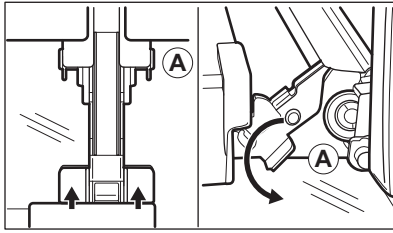

3. Close the oven door to the first opening position (approximately 70° angle).
4. Hold the door with one hand on each side and pull it away from the appliance at an upwards angle.
5. Put the door with the outer side down on a soft cloth on a stable surface. This is to prevent scratches.
6. Hold the door trim (B) on the top edge of the door at the two sides and push inwards to release the clip seal.

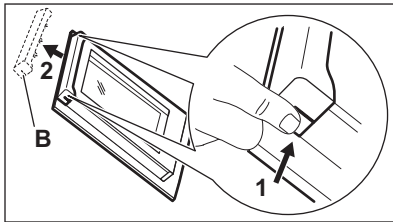

7. Pull the door trim to the front to remove it.
8. Hold the door glass panels on their top edge one by one and pull them up out of the guide.

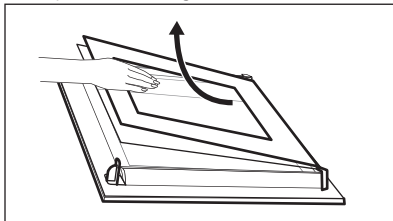

9. Clean the glass panel with water and soap. Dry the glass panel carefully. When the cleaning is completed, install the glass panels and the door. Do the above steps in the opposite sequence. Install the smaller panel first, then the larger.

12.6 Replacing the lamp

Put a cloth on the bottom of the interior of the appliance. It prevents damage to the lamp glass cover and the cavity.



WARNING!

Danger of electrocution!
Disconnect the fuse before you replace the lamp.
The lamp and the lamp glass cover can be hot.

1. Deactivate the appliance.
2. Remove the fuses from the fuse box or deactivate the circuit breaker.

The top lamp

1. Turn the lamp glass cover counterclockwise to remove it.

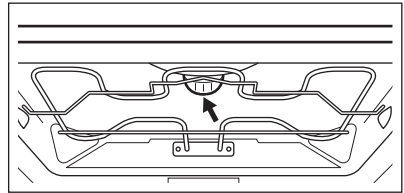

2. Clean the glass cover.
3. Replace the lamp with a suitable 300 °C heat-resistant lamp.
4. Install the glass cover.

The side lamp

1. Remove the left shelf support to get access to the lamp.
2. Use a narrow, blunt object (e.g. a teaspoon) to remove the glass cover.

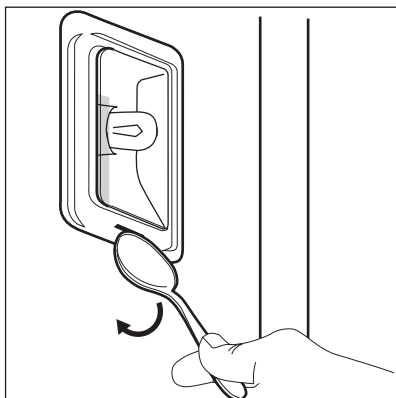



3. Clean the glass cover.
4. Replace the lamp with a suitable 300 °C heat-resistant lamp.
5. Install the glass cover.
6. Install the left shelf support.

13. TROUBLESHOOTING



WARNING!
Refer to Safety chapters.

13.1 What to do if...

Problem	Possible cause	Remedy
The oven does not heat up.	The oven is deactivated.	Activate the oven.
The oven does not heat up.	The clock is not set.	Set the clock.
The oven does not heat up.	The necessary settings are not set.	Make sure that the settings are correct.
The oven does not heat up.	The automatic switch-off is activated.	Refer to "Automatic switch-off".
The oven does not heat up.	The Child Lock is on.	Refer to "Using the Child Lock".
The oven does not heat up.	The fuse is released.	Make sure that the fuse is the cause of the malfunction. If the fuse releases again and again, contact a qualified electrician.
The lamp does not operate.	The lamp is defective.	Replace the lamp.
The display does not show the time during the off status.	The display is deactivated.	Touch  and  at the same time to activate the display again.
The core temperature sensor does not operate.	The plug of the core temperature sensor is not correctly installed into the socket.	Put the plug of the core temperature sensor as far as possible into the socket.

Problem	Possible cause	Remedy
It takes too long to cook the dishes or they cook too quickly.	The temperature is too low or too high.	Adjust the temperature if necessary. Follow the advice in the user manual.
Steam and condensation settle on the food and in the cavity of the oven.	You left the dish in the oven for too long.	Do not leave the dishes in the oven for longer than 15 - 20 minutes after the cooking process ends.
The display shows "C2".	You want to start the Pyrolysis or the Defrost function, but you did not remove the core temperature sensor plug from the socket.	Remove the core temperature sensor plug from the socket.
The display shows "C3".	The cleaning function does not operate. You did not fully close the door, or the door lock is defective.	Fully close the door.
The display shows "F102".	<ul style="list-style-type: none"> You did not fully close the door. The door lock is defective. 	<ul style="list-style-type: none"> Fully close the door. Deactivate the oven with the house fuse or the safety switch in the fuse box and activate it again. If the display shows "F102" again, contact the Customer Care Department.
The display shows an error code that is not in this table.	There is an electrical fault.	<ul style="list-style-type: none"> Deactivate the oven with the house fuse or the safety switch in the fuse box and activate it again. If the display shows the error code again, contact the Customer Care Department.

13.2 Service data

If you cannot find a solution to the problem yourself, contact your dealer or an Authorised Service Centre.

The necessary data for the service centre is on the rating plate. The rating plate is

on the front frame of the appliance cavity. Do not remove the rating plate from the appliance cavity.

We recommend that you write the data here:

Model (MOD.)

We recommend that you write the data here:

Product number (PNC)

Serial number (S.N.)

14. ENERGY EFFICIENCY

14.1 Product Fiche and information according to EU 65-66/2014

Supplier's name	AEG	
Model identification	BP7004021M BP730400KM	
Energy Efficiency Index	92.9	
Energy efficiency class	A	
Energy consumption with a standard load, conventional mode	0.99 kWh/cycle	
Energy consumption with a standard load, fan-forced mode	0.79 kWh/cycle	
Number of cavities	1	
Heat source	Electricity	
Volume	71 l	
Type of oven	Built-In Oven	
Mass	BP7004021M	41.5 kg
	BP730400KM	42.0 kg

EN 60350-1 - Household electric cooking appliances - Part 1: Ranges, ovens, steam ovens and grills - Methods for measuring performance.

14.2 Energy saving

The appliance contains features which help you save energy during everyday cooking.



- **General hints**

- Make sure that the oven door is closed properly when the appliance operates and keep it closed as much as possible during the cooking.
- Use metal dishes to improve the energy saving.

- When possible, put the food inside the oven without heating it up.
- When the cooking duration is longer than 30 minutes, reduce the oven temperature to minimum, 3 - 10 minutes before the end of the cooking time, depending on the duration of the cooking. The residual heat inside the oven will continue to cook.
- Use the residual heat to warm up other foods.
- **Cooking with fan** - when possible, use the cooking functions with fan to save energy.
- **Residual heat**
 - In some oven functions if a programme with time selection (Duration, End, Time Delay) is

activated and the cooking time is longer than 30 minutes, the heating elements deactivate automatically 10% earlier. The fan and lamp continue to operate.

- **Cooking with the lamp off** - deactivate the lamp during the cooking and activate only when you need it.
- **Keep food warm** - if you want to use the residual heat to keep the meal warm, choose the lowest possible temperature setting. The display shows the residual heat temperature.
- **Eco functions** - refer to "Oven functions".

- When you use the **Moist Fan Baking** function, the lamp deactivates after 30 seconds. You can activate it again according to your preferences.
- When you use the **ECO functions**, the lamp deactivates. You can activate it again according to your preferences.
- **Deactivating the display** - If necessary, you can fully deactivate the display. Touch  and  at the same time until the display goes out. This step also activates the appliance.

15. ENVIRONMENT CONCERNS

Recycle the materials with the symbol . Put the packaging in applicable containers to recycle it. Help protect the environment and human health and to recycle waste of electrical and electronic appliances. Do not dispose appliances

marked with the symbol  with the household waste. Return the product to your local recycling facility or contact your municipal office.

www.aeg.com/shop



867303535-B-422014



 **AEG**
perfekt in form und funktion