



## CONTENTS

1. SAFETY INFORMATION.....	3
2. SAFETY INSTRUCTIONS.....	5
3. PRODUCT DESCRIPTION.....	7
4. BEFORE FIRST USE.....	8
5. HOB - DAILY USE.....	9
6. HOB - HINTS AND TIPS.....	13
7. HOB - CARE AND CLEANING.....	15
8. OVEN - DAILY USE .....	15
9. OVEN - CLOCK FUNCTIONS.....	21
10. OVEN - HINTS AND TIPS.....	21
11. OVEN - CARE AND CLEANING.....	31
12. TROUBLESHOOTING.....	34
13. INSTALLATION.....	36

## FOR PERFECT RESULTS

Thank you for choosing this AEG product. We have created it to give you impeccable performance for many years, with innovative technologies that help make life simpler features you might not find on ordinary appliances. Please spend a few minutes reading to get the very best from it.

Visit our website for:



Get usage advice, brochures, trouble shooter, service information:  
**[www.aeg.com](http://www.aeg.com)**



Register your product for better service:  
**[www.registeraeg.com](http://www.registeraeg.com)**



Buy Accessories, Consumables and Original spare parts for your appliance:  
**[www.aeg.com/shop](http://www.aeg.com/shop)**

## CUSTOMER CARE AND SERVICE

Always use original spare parts.

When contacting our Authorised Service Centre, ensure that you have the following data available: Model, PNC, Serial Number.

The information can be found on the rating plate.

 Warning / Caution-Safety information

 General information and tips

 Environmental information

Subject to change without notice.

## 1. SAFETY INFORMATION

Before the installation and use of the appliance, carefully read the supplied instructions. The manufacturer is not responsible if an incorrect installation and use causes injuries and damages. Always keep the instructions with the appliance for future reference.

### 1.1 Children and vulnerable people safety

**WARNING!**

Risk of suffocation, injury or permanent disability.

- This appliance can be used by children aged from 8 years and above and persons with reduced physical, sensory or mental capabilities or lack of experience and knowledge if they have been given supervision or instruction concerning use of the appliance in a safe way and understand the hazards involved.
- Do not let children play with the appliance.
- Keep all packaging away from children.
- Keep children and pets away from the appliance when it operates or when it cools down. Accessible parts are hot.
- If the appliance has a child safety device, we recommend you activate it.
- Cleaning and user maintenance shall not be made by children without supervision.

### 1.2 General Safety

- Only a qualified person must install this appliance and replace the cable.
- Do not operate the appliance by means of an external timer or separate remote-control system.
- Unattended cooking on a hob with fat or oil can be dangerous and may result in fire.

- Never try to extinguish a fire with water, but switch off the appliance and then cover flame e.g. with a lid or a fire blanket.
- Do not store items on the cooking surfaces.
- Do not use a steam cleaner to clean the appliance.
- Metallic objects such as knives, forks, spoons and lids should not be placed on the hob surface since they can get hot.
- If the glass ceramic surface / glass surface is cracked, switch off the appliance to avoid the possibility of electric shock.
- After use, switch off the hob element by its control and do not rely on the pan detector.
- Internally the appliance becomes hot when in operation. Do not touch the heating elements that are in the appliance. Always use oven gloves to remove or put in accessories or ovenware.
- Before maintenance cut the power supply.
- Ensure that the appliance is switched off before replacing the lamp to avoid the possibility of electric shock.
- Do not use harsh abrasive cleaners or sharp metal scrapers to clean the glass door since they can scratch the surface, which may result in shattering of the glass.
- If the supply cord is damaged, it must be replaced by the manufacturer, its Authorised Service Centre or similarly qualified persons in order to avoid a hazard.
- Only use the core temperature sensor recommended for this appliance.
- To remove the shelf supports first pull the front of the shelf support and then the rear end away from the side walls. Install the shelf supports in the opposite sequence.
- The means for disconnection must be incorporated in the fixed wiring in accordance with the wiring rules.

## 2. SAFETY INSTRUCTIONS

### 2.1 Installation



#### **WARNING!**

Only a qualified person must install this appliance.

- Remove all the packaging.
- Do not install or use a damaged appliance.
- Obey the installation instruction supplied with the appliance.
- Always be careful when you move the appliance because it is heavy. Always wear safety gloves.
- Do not pull the appliance by the handle.
- The kitchen cabinet and the recess must have suitable dimensions.
- Keep the minimum distance from the other appliances and units.
- Make sure that the appliance is installed below and adjacent safe structures.
- Parts of the appliance carry current. Close the appliance with furniture to prevent touching the dangerous parts.
- The sides of the appliance must stay adjacent to appliances or to units with the same height.
- Do not install the appliance on a platform.
- Do not install the appliance adjacent to a door or under a window. This prevents hot cookware to fall from the appliance when the door or the window is opened.
- Make sure to install a stabilizing means in order to prevent tipping of the appliance. Refer to Installation chapter.

with the power supply. If not, contact an electrician.

- Always use a correctly installed shockproof socket.
- Do not use multi-plug adapters and extension cables.
- Do not let mains cables touch or come near the appliance door, especially when the door is hot.
- The shock protection of live and insulated parts must be fastened in such a way that it cannot be removed without tools.
- Connect the mains plug to the mains socket only at the end of the installation. Make sure that there is access to the mains plug after the installation.
- If the mains socket is loose, do not connect the mains plug.
- Do not pull the mains cable to disconnect the appliance. Always pull the mains plug.
- Use only correct isolation devices: line protecting cut-outs, fuses (screw type fuses removed from the holder), earth leakage trips and contactors.
- The electrical installation must have an isolation device which lets you disconnect the appliance from the mains at all poles. The isolation device must have a contact opening width of minimum 3 mm.
- Fully close the appliance door, before you connect the mains plug to the mains socket.

### 2.2 Electrical Connection



#### **WARNING!**

Risk of fire and electrical shock.

- All electrical connections should be made by a qualified electrician.
- The appliance must be earthed.
- Make sure that the electrical information on the rating plate agrees

### 2.3 Use



#### **WARNING!**

Risk of injury and burns.  
Risk of electrical shock.

- Use this appliance in a household only.
- Do not change the specification of this appliance.
- Make sure that the ventilation openings are not blocked.
- Do not let the appliance stay unattended during operation.
- Deactivate the appliance after each use.

- Be careful when you open the appliance door while the appliance is in operation. Hot air can release.
- Do not operate the appliance with wet hands or when it has contact with water.
- Do not use the appliance as a work surface or as a storage surface.
- Users with a pacemaker must keep a distance of minimum 30 cm from the induction cooking zones when the appliance is in operation.

**WARNING!**

Risk of fire and explosion

- Fats and oil when heated can release flammable vapours. Keep flames or heated objects away from fats and oils when you cook with them.
- The vapours that very hot oil releases can cause spontaneous combustion.
- Used oil, that can contain food remnants, can cause fire at a lower temperature than oil used for the first time.
- Do not put flammable products or items that are wet with flammable products in, near or on the appliance.
- Do not let sparks or open flames to come in contact with the appliance when you open the door.
- Open the appliance door carefully. The use of ingredients with alcohol can cause a mixture of alcohol and air.

**WARNING!**

Risk of damage to the appliance.

- To prevent damage or discoloration to the enamel:
  - do not put ovenware or other objects in the appliance directly on the bottom.
  - do not put water directly into the hot appliance.
  - do not keep moist dishes and food in the appliance after you finish the cooking.
  - be careful when you remove or install the accessories.
- Discoloration of the enamel has no effect on the performance of the appliance. It is not a defect in the sense of the warranty law.

- Use a deep pan for moist cakes. Fruit juices cause stains that can be permanent.
- Do not keep hot cookware on the control panel.
- Do not let cookware boil dry.
- Be careful not to let objects or cookware fall on the appliance. The surface can be damaged.
- Do not activate the cooking zones with empty cookware or without cookware.
- Do not put aluminium foil on the appliance or directly on the bottom of the appliance.
- Cookware made of cast iron, aluminium or with a damaged bottom can cause scratches. Always lift these objects up when you have to move them on the cooking surface.
- This appliance is for cooking purposes only. It must not be used for other purposes, for example room heating.

## 2.4 Care and Cleaning

**WARNING!**

Risk of injury, fire, or damage to the appliance.

- Before maintenance, deactivate the appliance. Disconnect the mains plug from the mains socket.
- Make sure the appliance is cold. There is the risk that the glass panels can break.
- Replace immediately the door glass panels when they are damaged. Contact the Service.
- Be careful when you remove the door from the appliance. The door is heavy!
- Clean regularly the appliance to prevent the deterioration of the surface material.
- Remaining fat or food in the appliance can cause fire.
- Clean the appliance with a moist soft cloth. Only use neutral detergents. Do not use abrasive products, abrasive cleaning pads, solvents or metal objects.
- If you use an oven spray, obey the safety instructions on the packaging.

- Do not clean the catalytic enamel (if applicable) with any kind of detergent.

## 2.5 Internal light

- The type of light bulb or halogen lamp used for this appliance is only for household appliances. Do not use it for house lighting.



### WARNING!

Risk of electrical shock.

- Before replacing the lamp, disconnect the appliance from the power supply.

- Only use lamps with the same specifications.

## 2.6 Disposal



### WARNING!

Risk of injury or suffocation.

- Disconnect the appliance from the mains supply.
- Cut off the mains cable and discard it.
- Remove the door catch to prevent children and pets to get closed in the appliance.

# 3. PRODUCT DESCRIPTION

## 3.1 General overview

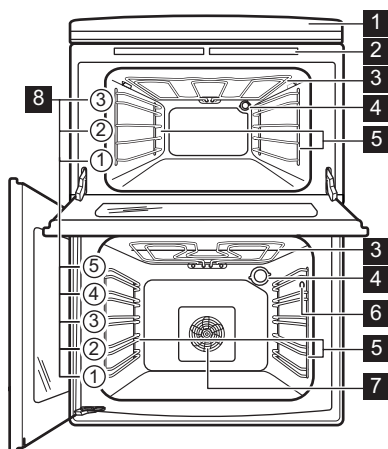

- 1 Control panel and hob
- 2 Air vents for the cooling fan
- 3 Heating element
- 4 Lamp
- 5 Shelf support, removable
- 6 Socket for the core temperature sensor
- 7 Fan
- 8 Shelf positions

## 3.2 Cooking surface layout

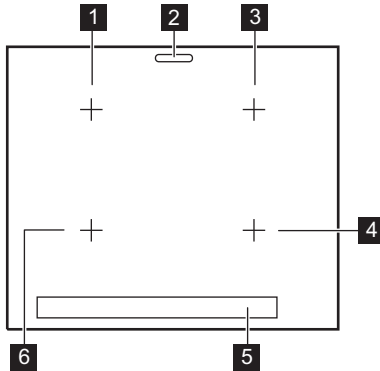

- 1 Induction cooking zone 2300 W with the Power function 3200 W
- 2 Steam outlet - number and position depend on the model
- 3 Induction cooking zone 2300 W with the Power function 3200 W
- 4 Induction cooking zone 2300 W with the Power function 3200 W
- 5 Control panel
- 6 Induction cooking zone 2300 W with the Power function 3200 W

## 3.3 Accessories

- **Wire shelf**  
For cookware, cake tins, roasts.
- **Grill- / Roasting pan**  
To bake and roast or as pan to collect fat.
- **Trivet**

For roasting and grilling.

**i** Use the trivet only with the Grill- / roasting pan.

- **Core temperature sensor**  
To measure how far the food is cooked.

## 4. BEFORE FIRST USE



**WARNING!**  
Refer to Safety chapters.

### 4.1 Initial Cleaning

Remove all accessories and removable shelf supports from the appliance.



Refer to "Care and cleaning" chapter.

Clean the appliance before first use.  
Put the accessories and the removable shelf supports back to their initial position.

### 4.2 Using the sensor fields

To activate a function touch and hold the selected symbol on the display for minimum 1 second.

### 4.3 Setting the time

You must set the time before you operate the oven.

When you connect the appliance to the electrical supply or after a power cut, the indicator for the Time function flashes.

Press the **+** or **-** to set the correct time.

After approximately five seconds, the flashing stops and the display shows the time of day you set.



You can only change the time if:

- The child safety device is not on.
- None of the clock functions Duration **|>|** or End **->|** is set.
- No oven function is set.

### 4.4 Preheating

Preheat the empty appliance to burn off the remaining grease.

**i** Preheat the two ovens. Heat up one oven at a time. Set the functions listed below, if applicable.

1. Set the function  and the maximum temperature.
2. Let the appliance operate for 1 hour.
3. Set the function  and the maximum temperature.

4. Let the appliance operate for 15 minutes.
5. Set the function  and the maximum temperature.
6. Let the appliance operate for 15 minutes.

Accessories can become hotter than usual. The appliance can emit an odour and smoke. This is normal. Make sure that the airflow in the room is sufficient.







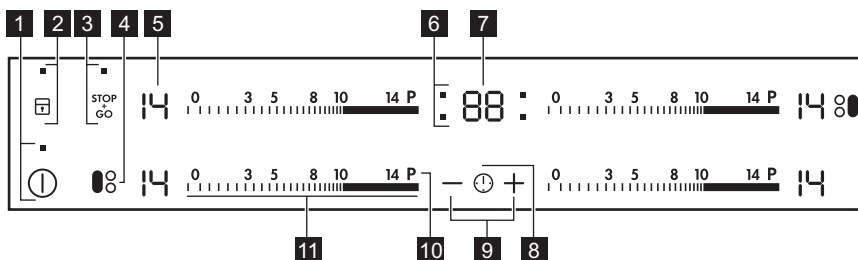





## 5. HOB - DAILY USE



**!** **WARNING!**  
Refer to Safety chapters.

### 5.1 Hob control panel















Use the sensor fields to operate the appliance. The displays, indicators and sounds tell which functions operate.

Sensor field	Function	Comment
 ①	ON / OFF	To activate and deactivate the hob.
 	Lock / The Child Safety Device	To lock / unlock the control panel.
 	STOP+GO	To activate and deactivate the function.
 	Bridge	To activate and deactivate the function.
 -	Heat setting display	To show the heat setting.
 -	Timer indicators of cooking zones	To show for which zone you set the time.
 -	Timer display	To show the time in minutes.
 	-	To select the cooking zone.

Sensor field	Function	Comment
 $\frac{+}{-}$	-	To increase or decrease the time.
 P	Power function	To activate and deactivate the function.
 -	Control bar	To set a heat setting.



## 5.2 Heat setting displays

Display	Description
	The cooking zone is deactivated.
 	The cooking zone operates.
	STOP+GO function operates.
	Automatic Heat Up function operates.
	Power function operates.
 + digit	There is a malfunction.
 /  / 	OptiHeat Control (3 step Residual heat indicator): continue cooking / keep warm / residual heat.
	Lock / The Child Safety Device function operates.
	Incorrect or too small cookware or no cookware on the cooking zone.
	Automatic Switch Off function operates.

## 5.3 OptiHeat Control (3 step Residual heat indicator)



### WARNING!

 /  /  There is a risk of burns from residual heat. The indicator shows the level of the residual heat.

The induction cooking zones make the heat necessary for cooking process directly in the bottom of the cookware. The glass ceramic is heated by the heat of the cookware.



## 5.4 Activating and deactivating

Touch  for 1 second to activate or deactivate the hob.

## 5.5 Automatic Switch Off

**The function deactivates the hob automatically if:**

- all cooking zones are deactivated,
- you do not set the heat setting after you activate the hob,
- you spill something or put something on the control panel for more than 10 seconds (a pan, a cloth, etc.). An acoustic signal sounds and the hob

- deactivates. Remove the object or clean the control panel.
- the hob gets too hot (e.g. when a saucepan boils dry). Let the cooking zone cool down before you use the hob again.
  - you use incorrect cookware. The symbol  comes on and the cooking zone deactivates automatically after 2 minutes.
  - you do not deactivate a cooking zone or change the heat setting. After some time  comes on and the hob deactivates.

**The relation between the heat setting and the time after which the hob deactivates:**

Heat setting	The hob deactivates after
 1 - 3	6 hours
4 - 7	5 hours
8 - 9	4 hours
10 - 14	1.5 hour

## 5.6 The heat setting

To set or change the heat setting:

Touch the control bar at the correct heat setting or move your finger along the control bar until you reach the correct heat setting.

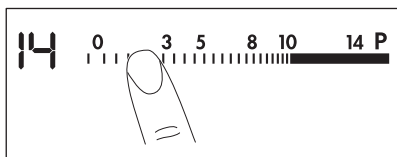



## 5.7 Bridge function

This function connects two cooking zones and they operate as one.

First set the heat setting for one of the cooking zones.



**To activate the function for left / right cooking zones:** touch . To set or change the heat setting touch one of the left / right control sensors.

**To deactivate the function:** touch  / . The cooking zones operate independently.

## 5.8 Automatic Heat Up

If you activate this function you can get a necessary heat setting in a shorter time. The function sets the highest heat setting for some time and then decreases to the correct heat setting.

 To activate the function the cooking zone must be cold.

**To activate the function for a cooking zone:** touch **P** ( comes on). Immediately touch the correct heat setting. After 3 seconds  comes on.

**To deactivate the function:** change the heat setting.

## 5.9 Power function

This function makes more power available to the induction cooking zones. The function can be activated for the induction cooking zone only for a limited period of time. After this time the induction cooking zone automatically sets back to the highest heat setting.

**To activate the function for a cooking zone:** touch **P**.  comes on.

**To deactivate the function:** change the heat setting.

## 5.10 Timer

### Count Down Timer

You can use this function to set how long the cooking zone should operate for a single cooking session.



**First set the cooking zone then set the function.** You can set the heat setting before or after you set the function.





**To set the cooking zone:** touch  again and again until the indicator of a necessary cooking zone comes on.

**To activate the function:** touch  of the timer to set the time (**00 - 99** minutes). When the indicator of the

cooking zone starts to flash slowly the time counts down.

**To see the remaining time:** set the cooking zone with . The indicator of the cooking zone starts to flash quickly. The display shows the remaining time.

**To change the time:** set the cooking zone with . Touch  or .

**To deactivate the function:** set the cooking zone with  and touch . The remaining time counts back to **00**. The indicator of the cooking zone goes out. To deactivate the function you can also touch  and  at the same time.

 When the time comes to an end, the sound operates and **00** flashes. The cooking zone deactivates.



**To stop the sound:** touch .

**CountUp Timer (The count up timer)**  
You can use this function to monitor how long the cooking zone operates.

**To set the cooking zone:** touch  again and again until the indicator of a necessary cooking zone comes on.



**To activate the function:** touch  of the timer. **UP** comes on. When the indicator of the cooking zone starts to flash slowly the time counts up. The display switches between **UP** and counted time (minutes).

**To see how long the cooking zone operates:** set the cooking zone with . The indicator of the cooking zone starts to flash quickly. The display shows how long the zone operates.

**To deactivate the function:** set the cooking zone with  and touch  or . The indicator of the cooking zone goes out.

**Minute Minder**  
You can use this function as a **Minute Minder** when the hob is activated and the cooking zones do not operate (the heat setting display shows .

**To activate the function:** touch .

Touch  or  of the timer to set the time. When the time comes to an end, the sound operates and **00** flashes.

**To stop the sound:** touch .

 The function has no effect on the operation of the cooking zones.

## 5.11 STOP+GO

This function sets all cooking zones that operate to the lowest heat setting.

When the function operates, you cannot change the heat setting.

The function does not stop the timer functions.

**To activate the function:** touch  comes on.

**To deactivate the function:** touch . The previous heat setting comes on.

## 5.12 Lock

You can lock the control panel while cooking zones operate. It prevents an accidental change of the heat setting.

**Set the heat setting first.**





**To activate the function:** touch  comes on for 4 seconds. The Timer stays on.

**To deactivate the function:** touch . The previous heat setting comes on.

 When you deactivate the hob, you also deactivate this function.

## 5.13 The Child Safety Device

This function prevents an accidental operation of the hob.

**To activate the function:** activate the hob with . Do not set the heat setting. Touch  for 4 seconds.  comes on. Deactivate the hob with .

**To deactivate the function:** activate the hob with ①. Do not set the heat setting. Touch **[T]** for 4 seconds. **[U]** comes on. Deactivate the hob with ①.

**To override the function for only one cooking time:** activate the hob with ①. **[L]** comes on. Touch **[T]** for 4 seconds.

**Set the heat setting in 10 seconds.** You can operate the hob. When you deactivate the hob with ① the function operates again.

## 5.14 OffSound Control (Deactivation and activation of the sounds)

Deactivate the hob. Touch ① for 3 seconds. The display comes on and goes out. Touch **[T]** for 3 seconds. **[b]** or **[b]**

comes on. Touch **+** of the timer to choose one of the following:

- **[b]** - the sounds are off
- **[b]** - the sounds are on

To confirm your selection wait until the hob deactivates automatically.

When the function is set to **[b]** you can hear the sounds only when:

- you touch ①
- Minute Minder comes down
- Count Down Timer comes down
- you put something on the control panel.

## 5.15 Power management function

- All cooking zones are connected as on the illustration.
- The hob and both ovens are connected to one phase.
- The phase has a maximum electricity load.
- The function divides the power within the appliance. The oven is more important than the hob.
- The function activates when the total electricity load in the appliance is exceeded.
- The function decreases the power on the cooking zones to prevent a circuit overload.
- The heat setting display of the reduced zones changes between two levels.

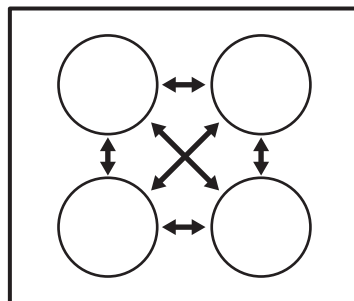

## 6. HOB - HINTS AND TIPS



**WARNING!**  
Refer to Safety chapters.

### 6.1 Cookware



For induction cooking zones a strong electro-magnetic field creates the heat in the cookware very quickly.



Use the induction cooking zones with correct cookware.

#### Cookware material

- **correct:** cast iron, steel, enamelled steel, stainless steel, the bottom made of multi-layer (with correct mark from a manufacturer).
- **not correct:** aluminium, copper, brass, glass, ceramic, porcelain.

#### Cookware is correct for an induction hob if:

- some water boils very quickly on a zone set to the highest heat setting.
- a magnet pulls on to the bottom of the cookware.



The bottom of the cookware must be as thick and flat as possible.

### Cookware dimensions

Induction cooking zones adapt to the dimension of the bottom of the cookware automatically to some limit.

The cooking zone efficiency is related to the diameter of the cookware. The cookware with a smaller diameter than the minimum receives only a part of the power generated by the cooking zone.

## 6.2 Minimum cookware diameter

Cooking zone	Minimum cookware diameter (mm)
Left rear	125
Right rear	125
Right front	125
Left front	125

## 6.3 The noises during operation

### If you can hear:

- crack noise: cookware is made of different materials (sandwich construction).

- whistle sound: you the cooking zone with high power level and the cookware is made of different materials (sandwich construction).
- humming: you use high power level.
- clicking: electric switching occurs.
- hissing, buzzing: the fan operates.

**The noises are normal and do not refer to hob malfunction.**

## 6.4 Energy saving

- If it is possible, always put the lids on the cookware.
- Put cookware on a cooking zone before you start it.
- Use the residual heat to keep the food warm or to melt it.

## 6.5 Examples of cooking applications

The relation between the heat setting and the cooking zone consumption of power is not linear. When you increase the heat setting, it is not proportional to the increase of the cooking zone consumption of power. It means that the cooking zone with the medium heat setting uses less than a half of its power.



The data in the table is for guidance only.

Heat setting	Use to:	Time (min)	Hints
1	Keep cooked food warm.	as necessary	Put a lid on the cookware.
1 - 3	Hollandaise sauce, melt: butter, chocolate, gelatine.	5 - 25	Mix from time to time.
1 - 3	Solidify: fluffy omelettes, baked eggs.	10 - 40	Cook with a lid on.
3 - 5	Simmer rice and milkbased dishes, heating up ready-cooked meals.	25 - 50	Add the minimum twice as much liquid as rice, mix milk dishes part procedure through.

Heat setting	Use to:	Time (min)	Hints
5 - 7	Steam vegetables, fish, meat.	20 - 45	Add some tablespoons of liquid.
7 - 9	Steam potatoes.	20 - 60	Use max. ¼ l water for 750 g of potatoes.
7 - 9	Cook larger quantities of food, stews and soups.	60 - 150	Up to 3 l liquid plus ingredients.
9 - 12	Gentle fry: escalope, veal cordon bleu, cutlets, rissoles, sausages, liver, roux, eggs, pancakes, doughnuts.	as necessary	Turn halfway through.
12 - 13	Heavy fry, hash browns, loin steaks, steaks.	5 - 15	Turn halfway through.
14	Boil water, cook pasta, sear meat (goulash, pot roast), deep-fry chips.		
	Boil large quantities of water. Power function is activated.		

## 7. HOB - CARE AND CLEANING



### WARNING!

Refer to Safety chapters.

### 7.1 General information

- Clean the hob after each use.
- Always use cookware with clean bottom.
- Scratches or dark stains on the surface have no effect on how the hob operates.
- Use a special cleaner applicable for the surface of the hob.
- Use a special scraper for the glass.

### 7.2 Cleaning the hob

- **Remove immediately:** melted plastic, plastic foil, and food with sugar. If not, the dirt can cause damage to the hob. Put the special scraper on the glass surface at an acute angle and move the blade on the surface.
- **Remove when the hob is sufficiently cool:** limescale rings, water rings, fat stains, shiny metallic discoloration. Clean the hob with a moist cloth and some detergent. After cleaning, rub the hob dry with a soft cloth.

## 8. OVEN - DAILY USE



### WARNING!

Refer to Safety chapters.

## 8.1 Oven Control Panel

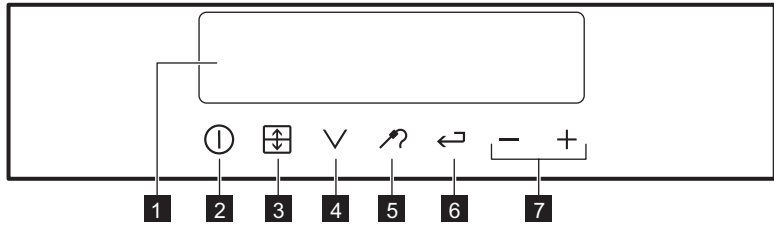

Use the sensor fields to operate the appliance

Sensor field	Function	Comment
1	–	Display Shows the current settings of the appliance.
2	⓪	ON / OFF To activate or deactivate the oven.
3	⬆️⬆️	Oven selection To move between top and main oven.
4	∨	Down key To move in the menu and to set an oven function or programme
5	👉	Core temperature sensor To activate the Core temperature sensor function.
6	⬅️	Return / Clock function selection To go back one level in the menu. To set the clock functions.
7	– / +	Increase / Decrease To set the time and temperature value.



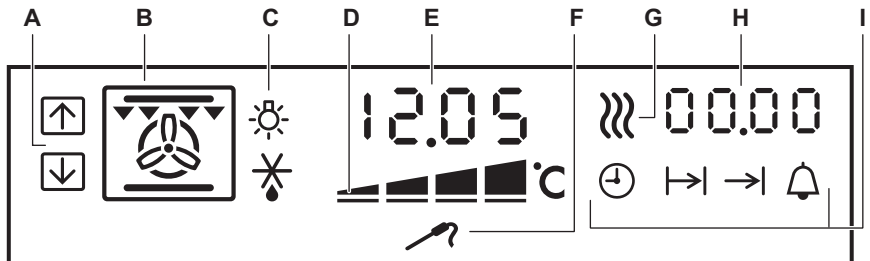

## 8.2 Indicators on the display



Name	Description
A Top / Main oven indicator	Shows which oven operates.



















	Name	Description
B	Oven function indicator	Shows the function which is active.
C	Lamp / Defrost indicator	Shows that the Lamp / Defrost function is active.
D	Heat-up and residual heat indicator	Shows that the Heat-up / residual heat is active.
E	Temperature / Clock indicator	Shows the temperature and the time in minutes.
F	Core temperature sensor indicator	Shows that the core temperature sensor is in the socket.
G	Keep warm indicator	Shows that keep warm function is active.
H	Cooking time / End time / Period of operation	Shows the time setting for clock functions.
I	Clock function indicators	Shows the clock function which is active.

### 8.3 Top oven functions



Symbol	Oven function	Application
	Conventional Cooking	To bake and roast food on 1 shelf position.
	Browning	To roast larger meat joints or poultry with bones on 1 shelf position. Also to make gratins and to brown.
	Bottom Heat	To bake cakes with crispy bottom and to preserve food.
	Dual Grill	To grill flat food in large quantities and to toast bread.
	Oven Lamp	To activate the lamp without a cooking function.

### 8.4 Main oven functions

Symbol	Oven function	Application
	Thermaflow®	To bake on up to 2 shelf positions at the same time and to dry food. Set the temperature 20 - 40 °C lower than for Conventional Cooking.

Symbol	Oven function	Application
 	Conventional Cooking	To bake and roast food on 1 shelf position.
 	Pie/Pizza	To bake food on 1 shelf position for a more intensive browning and a crispy bottom. Set the temperature 20 - 40 °C lower than for Conventional Cooking.
 	Low Temperature Cooking	To prepare very lean, tender roasted food.
 	Thermal Grilling	To roast larger meat joints or poultry with bones on 1 shelf position. Also to make gratins and to brown.
 	Dual Grill	To grill flat food in large quantities and to toast bread.
 	Keep Warm	To keep food warm.
 	Drying	To dry sliced fruit (e.g. apples, plums, peaches) and vegetables (e.g. tomatoes, zucchini, mushrooms).
 	Defrost	To defrost frozen food.
 	Oven Lamp	To activate the lamp without a cooking function.

## 8.5 Activating and deactivating

1. Press  to activate the oven.
2. Repeatedly press  to select the top or main oven.



## 8.6 Setting the oven function

 You can change the oven function while the oven operates.

Press  to set an oven function. The display shows the recommended temperature.

If you do not change the this temperature in less than approximately 5 seconds, the appliance starts to heat.

## 8.7 Changing the oven temperature

Press  or  to change the temperature. When the appliance is at the set temperature, an acoustic signal sounds.

## 8.8 Deactivating an oven function

Repeatedly touch  until no oven function shows in the display.

## 8.9 Heat-up indicator

When you activate an oven function, the bars on the display come on one by one. The bars show that the oven temperature increases.

## 8.10 Residual heat indicator

When you deactivate the oven, the display shows the residual heat.

## 8.11 Cooling fan

When the appliance operates, the cooling fan activates automatically to keep the surfaces of the appliance cool. If you deactivate the appliance, the cooling fan can continue to operate until the appliance cools down.

## 8.12 Oven automatic switch-off

For safety reasons the appliance deactivates automatically after some time if a heating function operates and you do not change any settings.

Temperature	Switch-off time
30 °C - 115 °C	12.5 h
120 °C - 195 °C	8.5 h
200 °C - 245 °C	5.5 h
250 °C - maximum °C	3.0 h

After the Automatic switch-off, press a sensor field to operate the appliance again.

**i** The oven automatic switch-off does not work with the Duration or End function.

## 8.13 Using the Core temperature sensor

The core temperature sensor measures the core temperature of the meat.

**!** **CAUTION!** Only use the core temperature sensor supplied with the appliance, or genuine replacement parts.

1. Put the point of the core temperature sensor into the centre of the meat. Make sure that the core temperature sensor stays in the meat and in the socket during the cooking.

2. Put the plug of the core temperature sensor into the socket on the side of the appliance.

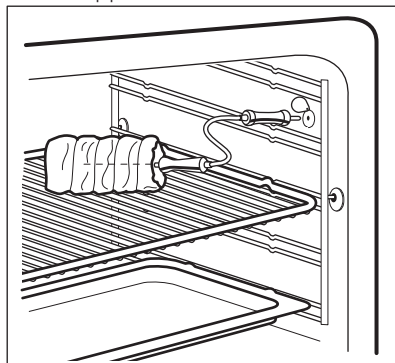

3. Activate the appliance.
4. Press  $\updownarrow$  again and again until the main oven appears.
5. Set the core temperature:
  - a. Press  $\uparrow$  again and again until the function core temperature sensor flashes and the display shows the core temperature.

**i** The default core temperature is 60 °C.

- b. Press  $+$  or  $-$  in less than 5 seconds to set the core temperature.

The core temperature is displayed from 30 °C.

6. Set the oven function and, if necessary, the oven temperature  $+$  /  $-$ .

While the appliance calculates the approximate end time, the display shows a square that flashes.

The appliance calculates the approximate end time for the set core temperature again and again. The display constantly shows the new approximate end time.

7. Press a button to stop the signal. An acoustic signal sounds, when the meat is at the set core temperature.
8. Remove the plug of the core temperature sensor from the socket. Remove the meat from the appliance.
9. Deactivate the appliance.

**WARNING!**

Be careful when you remove the tip and plug of the core temperature sensor. The core temperature sensor is hot. There is a risk of burns.

## 8.14 Inserting the oven accessories

### Deep pan:

Push the deep pan between the guide bars of the shelf support.

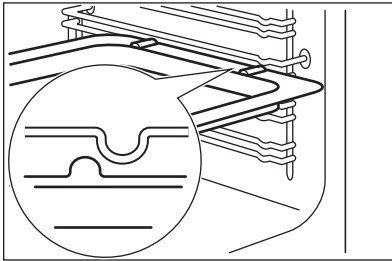

### Wire shelf and the deep pan together:

Push the deep pan between the guide bars of the shelf support and the wire shelf on the guide bars above.

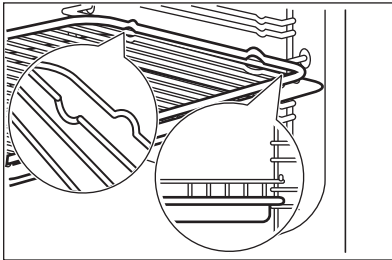

- All accessories have small indentations at the top of the right and left side to increase safety. The indentations are also anti-tip devices.
- The high rim around the shelf is a device which prevents cookware from slipping.

## 8.15 Trivet and Grill- / Roasting pan

**WARNING!**

Be careful when you remove the accessories from a hot appliance. There is a risk of burns.

You can use the trivet to roast larger pieces of meat or poultry on one shelf position.

1. Put the trivet into the deep pan so that the supports of the wire shelf point up.

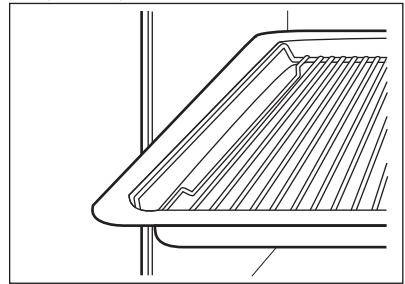

2. Put the deep pan into the oven on the necessary shelf position. You can use the trivet to grill flat dishes in large quantities and to toast.



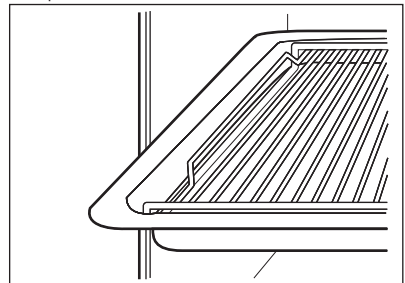

1. Put the trivet into the deep pan so that the supports of the wire shelf point down.







2. Put the deep pan into the oven on the necessary shelf position.



## 9. OVEN - CLOCK FUNCTIONS



### 9.1 Clock functions table

Clock function	Application
 Time of day	To set, change or check the time of day.
 Minute Minder	To set countdown time. This function has no effect on the operation of the appliance.
 Duration	To set the cooking time of the oven.
 End	To set the time of day when the oven should deactivate.

 You can use the functions Duration  and End  at the same time to set the time for how long the appliance should operate and when the appliance should deactivate. This lets you activate the appliance with a delay in time. First set the Duration  and then the End .

### 9.2 Setting the clock functions

For Duration  and End  set the oven function and temperature. This is not necessary for the Minute Minder . Refer to "Setting an oven function".



1. Use  again and again until the display shows the necessary clock function.
2. Use  or  to set the necessary time.

The clock function operates. The display shows the indicator for the clock function you set.

When the time ends the indicator of the clock function and "00.00" flash and an

acoustic signal sounds for 2 minutes. The appliance deactivates.





Touch a sensor field to stop the acoustic signal.

 With Duration  and End , the oven deactivates automatically.

### 9.3 Activating Heat + Hold (if applicable)

 The temperature for the set oven function must be above 80°C.

The Heat+Hold function keeps prepared food warm for 30 minutes after the cooking is completed.

1. Set the time with the clock functions Duration  and / or End .
2. Press  again and again until the display shows the symbol Keep warm .
3. Use  and the display shows "00:30".

When the function ends, an acoustic signal sounds. The oven deactivates automatically.

## 10. OVEN - HINTS AND TIPS



### WARNING!

Refer to Safety chapters.



The temperature and baking times in the tables are guidelines only. They depend on the recipes and the quality and quantity of the ingredients used.

## 10.1 Top oven

The top oven is the smaller of the two ovens. It has 3 shelf positions. Use it to cook smaller quantities of food. It gives especially good results when used to cook fruitcakes, sweets and savoury flants or quiche.

## 10.2 Main oven

The main oven is particularly suitable for cooking larger quantities of food.

## 10.3 Baking

- Your oven can bake or roast differently to the appliance you had before. Adapt your usual settings

(temperature, cooking times) and shelf positions to the values in the tables.

- The manufacturer recommends that you use the lower temperature the first time.
- If you cannot find the settings for a special recipe, look for the one that is almost the same.
- You can extend baking times by 10 – 15 minutes if you bake cakes on more than one shelf position.
- Cakes and pastries at different heights do not always brown equally at first. If this occurs, do not change the temperature setting. The differences equalize during the baking procedure.
- With longer baking times, you can deactivate the oven approximately 10 minutes before the end of the baking time and then use the residual heat.

When you cook frozen food, the trays in the oven can twist during baking. When the trays become cold again, the distortions are gone.

## 10.4 Tips on baking

Baking results	Possible cause	Remedy
The bottom of the cake is not browned sufficiently.	The shelf position is incorrect.	Put the cake on a lower shelf.
The cake sinks and becomes soggy, lumpy or streaky.	The oven temperature is too high.	The next time you bake, set a slightly lower oven temperature.
The cake sinks and becomes soggy, lumpy or streaky.	The baking time is too short.	Set a longer baking time. <b>You cannot decrease baking times by setting higher temperatures.</b>
The cake sinks and becomes soggy, lumpy or streaky.	There is too much liquid in the mixture.	Use less liquid. Be careful with mixing times, especially if you use a mixing machine.
The cake is too dry.	The oven temperature is too low.	The next time you bake, set a higher oven temperature.
The cake is too dry.	The baking time is too long.	The next time you bake, set a shorter baking time.

Baking results	Possible cause	Remedy
The cake browns unevenly.	The oven temperature is too high and the baking time is too short.	Set a lower oven temperature and a longer baking time.
The cake browns unevenly.	The mixture is unevenly distributed.	Spread the mixture evenly on the baking tray.
The cake is not ready in the baking time given.	The oven temperature is too low.	The next time you bake, set a slightly higher oven temperature.

## 10.5 Conventional Baking - Top Oven

Food	Temperature (°C)	Time (min)	Shelf position
Biscuits	170 - 190	10 - 20	2
Bread	200 - 220	30 - 35	2
Bread rolls / buns	200 - 220	10 - 15	2
Cakes: Small & Queen	160 - 180	18 - 25	2
Cakes: Sponges	160 - 175	20 - 30	2
Cakes: Victoria Sandwich	160 - 170	18 - 25	2
Cakes: Madeira	140 - 150	75 - 90	2
Cakes: Rich Fruit	140 - 150	120 - 150	2
Cakes: Gingerbread	140 - 150	80 - 90	2
Cakes: Meringues	90 - 100	150 - 180	2
Cakes: Flapjack	160 - 170	25 - 30	2
Cakes: Shortbread	130 - 150	45 - 60	2
Cakes: Apple Pie	170 - 180	50 - 60	2
Casseroles: Beef / Lamb	160 - 170	150 - 180	2
Casseroles: Chicken	160 - 180	80 - 90	2
Convenience Foods	Follow manufacturer's instructions.		2
Fish	170 - 190	20 - 30	2
Fish Pie (Potato Topped)	190 - 200	20 - 30	2
Fruit Pies, Crumbles	190 - 200	30 - 50	2
Milk Puddings	150 - 170	90 - 120	2
Pasta Lasagne etc.	170 - 180	40 - 50	2

Food	Temperature (°C)	Time (min)	Shelf position
Pastry: Choux	180 - 190	30 - 40	2
Pastry: Eclairs, Profiteroles	180 - 190	30 - 40	2
Pastry: Flaky / Puff Pies	210 - 220	30 - 40	2
Shortcrusts: Mince Pies	190 - 200	15 - 20	2
Shortcrusts: Meat Pies	190 - 210	25 - 35	2
Shortcrusts: Quiche, Tarts, Flans	180 - 200	25 - 50	2
Scones	220 - 230	8 - 12	3
Shepard's Pie	190 - 200	30 - 40	2
Souffles	170 - 180	20 - 30	2
Vegetables: Baked Jacket Potatoes	180 - 190	60 - 90	2
Vegetables: Roast Potatoes	180 - 190	60 - 90	2
Yorkshire Pudding Large	220 - 210	25 - 40	2
Yorkshire Pudding Individual	210 - 220	15 - 25	2
Roasting Meat, Poultry	Refer to the Roasting table.		2

## 10.6 Conventional Baking - Main oven

Food	Temperature (°C)	Time (min)	Shelf position
Biscuits	180 - 190	10 - 20	3
Bread	200 - 220	30 - 35	3
Cakes: Small & Queen	160 - 180	18 - 25	3
Cakes: Sponges	170 - 180	20 - 25	3
Cakes: Madeira	150 - 160	60 - 80	3
Cakes: Rich Fruit	140 - 150	120 - 150	2
Cakes: Christmas	140 - 150	180 - 270	2
Cakes: Apple Pie	170 - 180	50 - 60	2
- Shortbread	140 - 160	45 - 60	3
Fish	170 - 190	30 - 40	3
Fruit Pies, Crumbles	180 - 200	30 - 50	3
Milk Puddings	150 - 170	60 - 90	3

Food	Temperature (°C)	Time (min)	Shelf position
Pastry: Choux	180 - 190	30 - 40	3
Pastry: Shortcrust	190 - 200	25 - 35	3
Pastry: Flaky	190 - 210	30 - 40	3
Choux Pastry	6	30 - 35	3
Pastry: Puff	Follow manufacturer's instructions. Reduce the temperature for Fan oven by 20 °C.		3
Plate Tarts	190 - 200	25 - 45	3
Quiches / Flans	200 - 210	25 - 45	3
Scones	220 - 230	8 - 12	3
Roasting: Meat, Poultry	170 - 190	Refer to the Roasting table.	3

## 10.7 Thermaflow® Baking - Main Oven



Shelf positions are not critical but ensure that the oven accessories are evenly spaced when more than one is used.

Food	Temperature (°C)	Time (min)	Shelf position
Biscuits	180 - 190	10 - 20	1 - 3
Bread	190 - 210	30 - 35	2
Cakes: Small & Queen	150 - 170	18 - 25	1 - 3
Cakes: Sponges	160 - 170	20 - 25	3
Cakes: Madeira	140 - 160	60 - 80	3
Cakes: Rich Fruit	130 - 140	120 - 150	3
Cakes: Christmas	130 - 140	180 - 270	3
Cakes: Apple Pie	160 - 170	50 - 60	3
- Shortbread	130 - 150	45 - 60	1 - 3
Fish	160 - 180	30 - 40	3
Fruit Pies, Crumbles	170 - 180	30 - 50	3

Food	Temperature (°C)	Time (min)	Shelf position
Milk Puddings	140 - 160	60 - 90	3
Pastry: Choux	180 - 190	30 - 40	3
Pastry: Shortcrust	180 - 190	25 - 35	3
Pastry: Flaky	180 - 190	30 - 40	3
Pastry: Puff	Follow manufacturer's instructions. Reduce the temperature for Fan oven by 20 °C.		3
Plate Tarts	180 - 190	25 - 45	3
Quiches / Flans	170 - 180	25 - 45	3
Scones	210 - 230	8 - 12	1 - 3
Roasting: Meat, Poultry	160 - 180	Refer to the Roasting table.	2

## 10.8 Pizza Setting

Food	Temperature (°C)	Time (min)	Shelf position
Apple Pie	160 - 180	50 - 60	2
Plate Tart	180 - 200	25 - 50	2
Pizza, frozen	Follow manufacturer's instructions		3
Pizza, home made	200 - 230	15 - 25	2
Quiches / Tarts	180 - 200	30 - 50	2

## 10.9 Roasting

- Use heat-resistant ovenware to roast (refer to the instructions of the manufacturer).
- You can roast large roasting joints directly in the deep pan (if present) or on the wire shelf above the deep pan.
- Roast lean meats in the roasting tin with the lid. This keeps the meat more succulent.
- All types of meat that can be browned or have crackling can be roasted in the roasting tin without the lid.
- We recommend that you cook meat and fish weighing 1 kg and above in the appliance.
- To prevent the meat juices or fat from burning onto the pan, put some liquid into the deep pan.
- If necessary, turn the roast (after 1/2 - 2/3 of the cooking time).
- Baste large roasts and poultry with their juices several times during roasting. This gives better roasting results.
- You can deactivate the appliance approximately 10 minutes before the end of the roasting time, and use the residual heat.

## 10.10 Thermaflow® or Conventional Cooking - Main Oven

### Roasting

Food	Temperature (°C)	Time (min)
Beef / Beef boned	170 - 190	20 - 35 minutes per 0.5 kb (1 lb) and 20 - 30 minutes over
Mutton / Lamb	170 - 190	20 - 35 minutes per 0.5 kb (1 lb) and 25 - 35 minutes over
Pork / Veal / Ham	170 - 190	30 - 40 minutes per 0.5 kb (1 lb) and 30 - 40 minutes over
Chicken	180 - 200	20 - 25 minutes per 0.5 kb (1 lb) and 20 minutes over
Turkey / Goose	170 - 190	15 - 20 minutes per 0.5 kg (1 lb) up to 3.5 kg (7 lb) then 10 minutes per 0.5 kg (1 lb) over 3.5 kg (7 lb)
Duck	180 - 200	25 - 35 minutes per 0.5 kb (1 lb) and 25 - 30 minutes over
Pheasant	170 - 190	35 - 40 minutes per 0.5 kb (1 lb) and 35 - 40 minutes over
Rabbit	170 - 190	20 minutes per 0.5 kb (1 lb) and 20 minutes over

### 10.11 Grilling in general



#### WARNING!

Always grill with the oven door closed.

- **Always grill with the maximum temperature setting.**
- Set the shelf into the shelf position as recommended in the grilling table.
- Always set the deep pan to collect the fat into the first shelf position.
- Set the deep pan and the trivet as recommended in the grilling table.

- Grill only flat pieces of meat or fish.
- **Always preheat an empty oven with the grill functions for 5 minutes.**

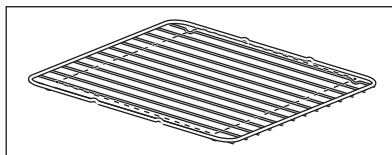

The grilling area is set in centre of the shelf.

### 10.12 Dual Circuit Grill - Top Oven

Food	Time (min)	Shelf position
Bacon Rashers	5 - 6	3
Beefburgers	10 - 20	3
Chicken Joints	20 - 40	2
Chops - Lamb	15 - 25	2 - 3
Chops - Pork	20 - 25	2 - 3

Food	Time (min)	Shelf position
Fish - Whole / Trout / Makarel	10 - 12	2
Fillets - Plaice / Cod	4 - 6	2
Kebabs	12 - 18	2 - 3
Kidneys - Lamb / Pig	6 - 10	2 - 3
Sausages	20 - 30	3
Steaks: Rare	4 - 6	3
Steaks: Medium	6 - 8	3
Steaks: Well Done	12 - 15	3
Toasted Sandwiches	3 - 4	3

### 10.13 Thermal Grilling - Main Oven

#### Roasting

Food	Quantity (kg)	Temperature (°C)	Time (min)	Shelf position
Beef: Pot roast	-	180 - 230	150 - 180	3
Beef: Topside beef or filler - rare	per cm of thickness	190 - 200	5 - 6	3
Beef: Topside beef or filler - medium	per cm of thickness	180 - 190	6 - 8	3
Beef: Topside beef or filler - well done	per cm of thickness	170 - 180	8 - 10	3
Pork: Shoulder, neck, ham	1 - 1.5	160 - 180	90 - 120	2
Pork: Pork chop	1 - 1.5	160 - 180	60 - 90	2
Pork: Meatloaf	0.75 - 1	160 - 170	45 - 60	2
Pork: Knuckle of pork (pre-cooked)	0.75 - 1	150 - 170	90 - 120	2
Veal: Roast veal	1	160 - 180	90 - 120	2
Veal: Knuckle of veal	1.5 - 2	160 - 180	120 - 150	2
Lamb: Roast lamb, leg of lamb	1 - 1.5	150 - 170	75 - 120	2
Lamb: Saddle of lamb	1 - 1.5	160 - 180	60 - 90	2

Food	Quantity (kg)	Temperature (°C)	Time (min)	Shelf position
Poultry	1 - 1.5	190 - 210	45 - 75	2
Half Chicken	0.5 - 1	190 - 210	35 - 50	2
Duck	1.5 - 2	180 - 200	75 - 105	1
Goose	3.5 - 5	160 - 180	135 - 210	1
Turkey	2.5 - 3.5	160 - 180	105 - 150	1
Turkey	4 - 6	140 - 160	150 - 240	1

## 10.14 Core temperature sensor table

### Beef

Food	Food core temperature (°C)	Shelf position
Roast beef	55 - 65	2 - 3
Rump steak - browning	55 - 65	2 - 3
Rump steak - roasting	55 - 65	2 - 3
Roast beef	75 - 80	1 - 2

### Veal

Food	Food core temperature (°C)	Shelf position
Fillet of beef	65	2 - 3

### Lamb

Food	Food core temperature (°C)	Shelf position
Leg / shoulder / saddle	90	2

### Pork

Food	Food core temperature (°C)	Shelf position
Roast pork	80	2 - 3
Neck fillets	75 - 80	2 - 3
Ham	70 - 75	1 - 2

## Poultry

Food	Food core temperature (°C)	Shelf position
Turkey breast	75 - 80	2 - 3

### 10.15 Low temperature cooking

Use the function to prepare lean, tender pieces of meat and fish.

The oven gets the pre set temperature and a signal operates. Then, the oven automatically sets to a lower temperature to continue cooking.



Always cook without a lid in Low Temperature Cooking. You cannot use Low temperature cooking together with the clock functions: Duration and End.

1. Sear the meat in the deep pan (if present) in a very high heat.
2. Put the meat in a roasting tin or directly on the wire shelf. Put the tray below the shelf to catch the fat.
3. Set oven function Low temperature cooking, change the temperature, if necessary, and cook until done (see the table).

Food	Quantity	Temperature (°C)	Preheating time (min)		Shelf position
			Rare	Medium	
Roast beef (well done)	800 - 1000 g	150	90 - 110	130 - 140	2
Roast beef (well done)	1200 - 1600 g	150	120 - 130	160 - 170	2
Rib of beef	600 - 1000 g	150	55 - 75	95 - 110	3
Shoulder of beef, boneless	3.5 cm high	150	-	70 - 80	3
Tenderloin of beef, whole	600 - 1000 g	120	65 - 75	90 - 110	3
Tenderloin of beef, sliced	2.5 cm high	120	20 - 25	35 - 45	3
Entrecote	1.5 cm high	120	15 - 25	30 - 35	3
T-bone	2 cm high	120	25 - 30	35 - 40	3
Tenderloin of pork, whole	500 - 700 g	120	-	65 - 75	3
Tenderloin of pork, sliced	2.5 cm high	120	-	35 - 45	2

### 10.16 Defrost

- Remove the food packaging. Put the food on a plate.
- Do not cover it with a bowl or a plate. This can extend the defrost time.
- Use the first oven shelf position. The one on the bottom.

Food	Quantity	Defrosting time (min)	Further defrosting time (min)	Comments
Chicken	1 kg	100 - 140	20 - 30	Put the chicken on an up-turned saucer in a big plate. Turn halfway through.
Meat	1 kg	100 - 140	20 - 30	Turn halfway through.
Meat	500 g	90 - 120	20 - 30	Turn halfway through.
Trout	150 g	25 - 35	10 - 15	-
Strawberries	300 g	30 - 40	10 - 20	-
Butter	250 g	30 - 40	10 - 15	-
Cream	2 x 200 g	80 - 100	10 - 15	Whip the cream when still slightly frozen in places.
Cake	1.4 kg	60	60	-

## 11. OVEN - CARE AND CLEANING



**WARNING!**  
Refer to Safety chapters.

### 11.1 Notes on cleaning

- Clean the front of the appliance with a soft cloth with warm water and a cleaning agent.
- To clean metal surfaces, use a usual cleaning agent.
- Clean the appliance interior after each use. Fat accumulation or other food remains may result in a fire. The risk is higher for the grill pan.
- Clean stubborn dirt with a special oven cleaner.
- Clean all accessories after each use and let them dry. Use a soft cloth with warm water and a cleaning agent.
- If you have nonstick accessories, do not clean them using aggressive agents, sharp-edged objects or a dishwasher. It can cause damage to the nonstick coating.

### 11.2 Stainless steel or aluminium appliances



Clean the oven door with a wet sponge only. Dry it with a soft cloth.  
Do not use steel wool, acids or abrasive materials as they can damage the oven surface. Clean the oven control panel with the same precautions.

### 11.3 Catalytic cleaning



**CAUTION!**  
Do not clean the catalytic surface with oven sprays, abrasive cleaning agents, soap or other cleaning agents. This will damage the catalytic surface.



Spots or discolouration of the catalytic surface have no effect on catalytic properties.

**WARNING!**

Keep children away when you clean the oven at a high temperature. The oven surface becomes very hot and there is a risk of burns.

**CAUTION!**

Always turn the oven light on while using the catalytic cleaning (if applicable).



Before activating the catalytic cleaning remove all the accessories from the oven.

The walls with a catalytic coating are self-cleaning. They absorb fat which collects on the walls while the appliance operates.

To support the self-cleaning procedure, heat the empty oven on a regular basis.

1. Clean the oven floor with warm water and washing up liquid, then dry it.
2. Set the  function.
3. Set the oven temperature to 250 °C and let the oven operate for 1 hour.
4. When the appliance is cool, clean it with a soft and moist sponge.

## 11.4 Removing the shelf supports

To clean the oven, remove the shelf supports.

1. Pull the front of the shelf support away from the side wall.

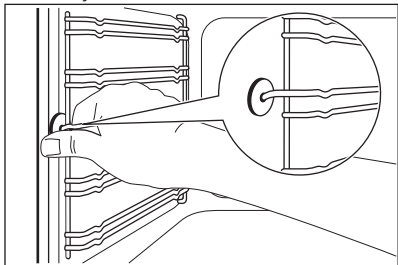

2. Pull the rear end of the shelf support away from the side wall and remove it.

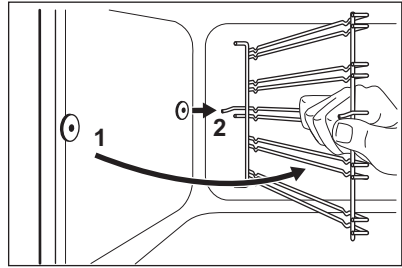

Install the shelf supports in the opposite sequence.

**CAUTION!**

Make sure that the longer fixing wire is in the front. The ends of the two wires must point to the rear. Incorrect installation can cause damage to the enamel.

## 11.5 Removing the oven door - top oven

To make the cleaning easier, remove the door.

1. Open the oven door about one-third of the way.

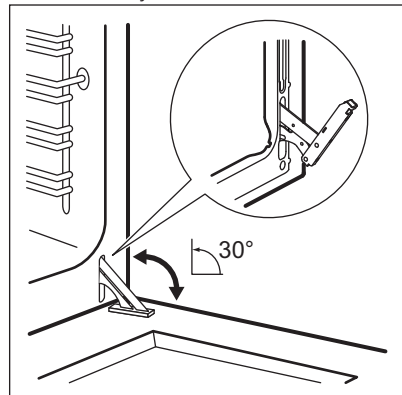

2. Hold the sides of the oven door with both hands and pull the door off the oven.

**CAUTION!**

Put the oven door with the outer side down on a soft material and level surface to prevent from scratches.

To install the door follow the procedure in reverse. Press down until the assembly spring clicks into the position.

## 11.6 Removing and cleaning the door glasses - top oven

**i** The door glass in your product can be different in type and shape from the examples you see in the image. The number of glasses can also be different.

1. Open the door.
2. Hold the door trim on the top edge of the door at the two sides and push inwards to release the clip seal.

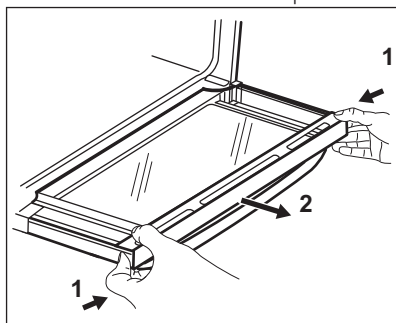

3. Pull the door trim to the front to remove it.
4. Remove the glass panels. To install the panels, do the same steps in reverse.

## 11.7 Removing and cleaning the door glasses - main oven

**i** The door glass in your product can be different in type and shape from the example you see in the image. The number of glasses can also be different.

1. Push the door trim at one side to remove it.

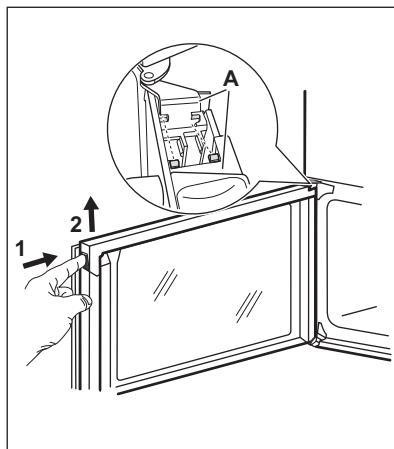

2. Pull up the trim.
3. Remove the glass panels.

**i** To replace the glass panels, do the same steps in reverse. Before you lower the trim, attach the A trim part to the door. Refer to the image.

## 11.8 Replacing the lamp

Put a cloth on the bottom of the interior of the appliance. It prevents damage to the lamp glass cover and the cavity.



### WARNING!

Danger of electrocution!  
Disconnect the fuse before you replace the lamp.  
The lamp and the lamp glass cover can be hot.

1. Deactivate the appliance.
2. Remove the fuses from the fuse box or deactivate the circuit breaker.

## The back lamp



The lamp glass cover is at the back of the cavity.

1. Turn the lamp glass cover counterclockwise to remove it.
2. Clean the glass cover.
3. Replace the oven lamp with a suitable 300 °C heat-resistant oven lamp.  
Use the same oven lamp type.
4. Install the glass cover.

## 12. TROUBLESHOOTING







### WARNING!

Refer to Safety chapters.

### 12.1 What to do if...

Problem	Possible cause	Remedy
You cannot activate the appliance.	The appliance is not connected to an electrical supply or it is connected incorrectly.	Check if the appliance is correctly connected to the electrical supply.
You cannot activate the appliance.	The fuse is released.	Make sure that the fuse is the cause of the malfunction. If the fuse releases again and again, contact a qualified electrician.
You cannot activate or operate the hob.	You touched 2 or more sensor fields at the same time.	Touch only one sensor field.
You cannot activate or operate the hob.	STOP+GO function operates.	Refer to "Hob - Daily use" chapter.
You cannot activate or operate the hob.	There is water or fat stains on the control panel.	Clean the control panel.
An acoustic signal sounds and the hob deactivates. An acoustic signal sounds when the hob is deactivated.	You put something on one or more sensor fields.	Remove the object from the sensor fields.
The hob deactivates.	You put something on the sensor field ①.	Remove the object from the sensor field.
Residual heat indicator does not come on.	The zone is not hot because it operated only for a short time.	If the zone operated sufficiently long to be hot, speak to an Authorised Service Centre.
Automatic Heat Up function does not operate.	The zone is hot.	Let the zone become sufficiently cool.
Automatic Heat Up function does not operate.	The highest heat setting is set.	The highest heat setting has the same power as the function.
The sensor fields become hot.	The cookware is too large or you put it too near to the controls.	Put large cookware on the rear zones if possible.
There is no signal when you touch the panel sensor fields.	The signals are deactivated.	Activate the signals. Refer to "Hob - Daily use" chapter.

<b>Problem</b>	<b>Possible cause</b>	<b>Remedy</b>
 comes on the hob display.	Automatic Switch Off operates.	Deactivate the hob and activate it again.
 comes on the hob display.	The Child Safety Device or the Lock function operates.	Refer to "Hob - Daily use" chapter.
 comes on the hob display.	There is no cookware on the zone.	Put cookware on the zone.
 comes on the hob display.	The cookware is incorrect.	Use the correct cookware. Refer to "Hob - Hints and tips" chapter.
 comes on the hob display.	The diameter of the bottom of the cookware is too small for the zone.	Use cookware with correct dimensions. Refer to "Hob - Hints and tips" chapter.
The oven does not heat up.	The oven is deactivated.	Activate the oven.
The oven does not heat up.	The clock is not set.	Set the clock.
The oven does not heat up.	The necessary settings are not set.	Make sure that the settings are correct.
The oven does not heat up.	The automatic switch-off is activated.	Refer to "Automatic switch-off".
The lamp does not operate.	The lamp is defective.	Replace the lamp.
The core temperature sensor does not operate.	The plug of the core temperature sensor is not correctly installed into the socket.	Put the plug of the core temperature sensor as far as possible into the socket.
It takes too long to cook the dishes or they cook too quickly.	The temperature is too low or too high.	Adjust the temperature if necessary. Follow the advice in the user manual.
Steam and condensation settle on the food and in the cavity of the oven.	You left the dish in the oven for too long.	Do not leave the dishes in the oven for longer than 15 - 20 minutes after the cooking process ends.
The display shows an error code that is not in this table.	There is an electrical fault.	Deactivate the appliance with the house fuse or the safety switch in the fuse box and activate it again. If the display shows the error code again, contact the Customer Care Department.

## 12.2 Service data

If you cannot find a solution to the problem yourself, contact your dealer or an Authorised Service Centre.

The necessary data for the service centre is on the rating plate. The rating plate is

on the front frame of the appliance cavity. Do not remove the rating plate from the appliance cavity.

We recommend that you write the data here:	
Model (MOD.)	.....
Product number (PNC)	.....
Serial number (S.N.)	.....

## 13. INSTALLATION



### WARNING!

Refer to Safety chapters.

### 13.1 Technical data

Dimensions	
Height	894 - 912 mm
Width	596 mm
Depth	600 mm
Top oven capacity	40 l
Main oven capacity	74 l

### 13.2 Location of the appliance

You can install your freestanding appliance with cabinets on one or two sides and in the corner.

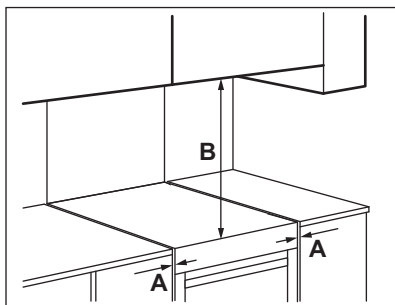

### Minimum distances

Dimension	mm
A	2
B	685

### 13.3 Levelling of the appliance

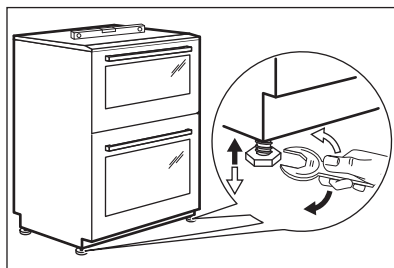

Use small feet on the bottom of appliance to set the appliance top surface level with other surfaces.

### 13.4 Anti-tilt protection

Adjust the appliance to the correct height and put it in the correct area before you attach the anti-tilt protection.

**CAUTION!**

Install the anti-tilt protection to prevent the appliance from falling under incorrect loads. The anti-tilt protection only works when the appliance is put in a correct area.

The anti-tilt protection has two parts (A + B). You can find the anti-tilt protection (B) on the right or left side of the rear wall of the appliance.

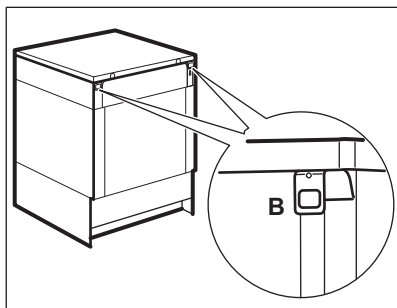

1. Install the anti-tilt protection (A) on the wall.  
Make sure that the wall is made of a solid material. If not, you need to make the wall sufficiently strong to hold the weight.  
Make sure that the surface behind the appliance is smooth.
2. Put the appliance in the middle of the space between the cupboards. If the space is larger than the width of the appliance, you must adjust the side measurement.
3. Install the anti-tilt protection (A) approximately 77 mm below the top surface of the appliance and 50 mm from the left or right side of the appliance into the circular hole on the bracket. Screw it into the wall.

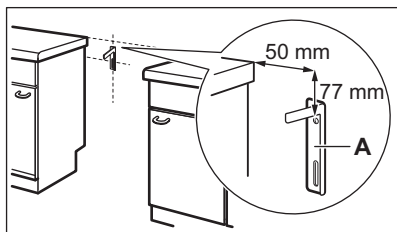

4. Check that the anti-tilt protection (A) fits minimum 20 mm into the hole in the rear wall of the appliance (B) when you push the appliance.

**13.5 Electrical installation****WARNING!**

The manufacturer is not responsible if you do not follow the safety precautions from Safety chapters.

This appliance is supplied without a main plug or a main cable.

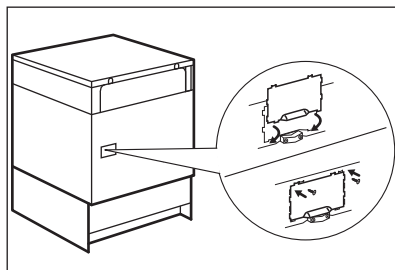
**13.6 Covering terminal board**

- The recommended cross-section area is six square millimetres (6 mm<sup>2</sup>).
- When you refit the mains terminal cover, make sure that the lower tabs are located inside the bottom edge of the aperture, before you fix the two screws into the top edge of the mains terminal cover.
- Make sure that the cover is securely fastened.



To open the cover of terminal board obey the procedure in opposite sequence.

**13.7 Terminal board**

Do not remove blanking plates.

Make sure that the links are fitted as shown.

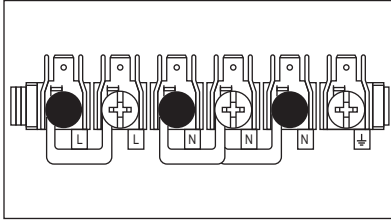

## 14. ENVIRONMENT CONCERNS

Recycle the materials with the symbol . Put the packaging in applicable containers to recycle it. Help protect the environment and human health and to recycle waste of electrical and electronic appliances. Do not dispose appliances

marked with the symbol  with the household waste. Return the product to your local recycling facility or contact your municipal office.



[www.aeg.com/shop](http://www.aeg.com/shop)



867307150-B-352014

